

Vacuum Pickup for automatic machine DLP6610

This is an attachment for adsorption of screws for an automatic screw fastening machine.

Flanged coupling DLW9015, sleeve DLS2124, DLS2127, and DLS2134 are attached.

(At shipment, the flanged coupling and sleeve DLS2127 are mounted.)

For details, read the instruction manual for the electric screwdriver.

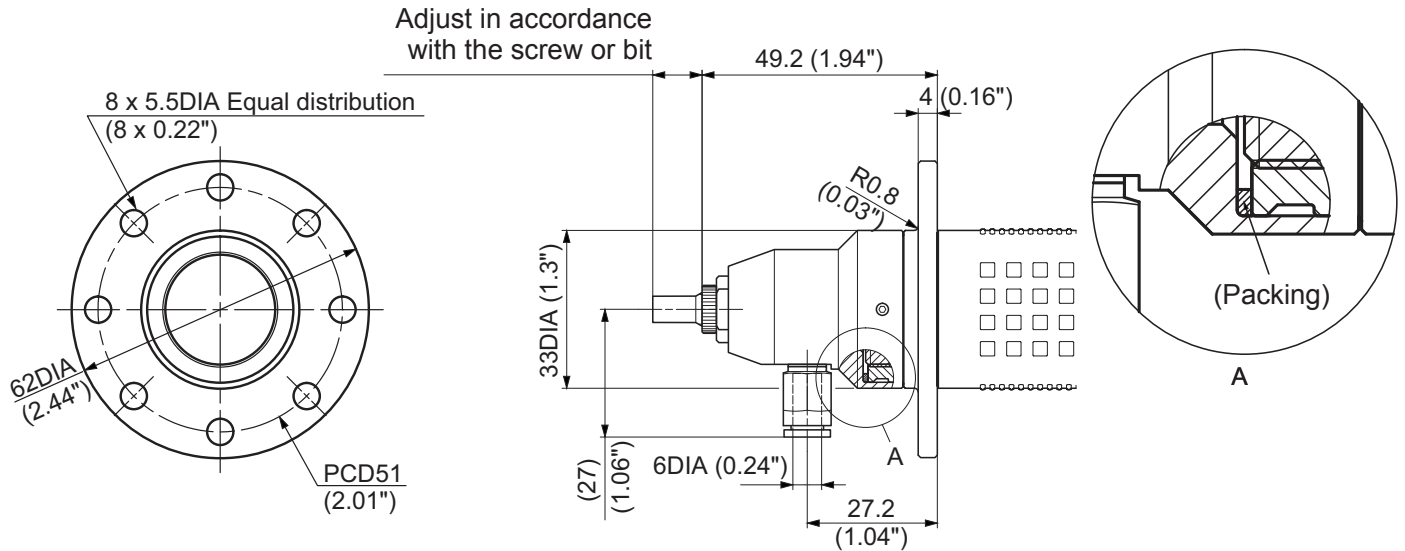

When only flanged coupling is mounted

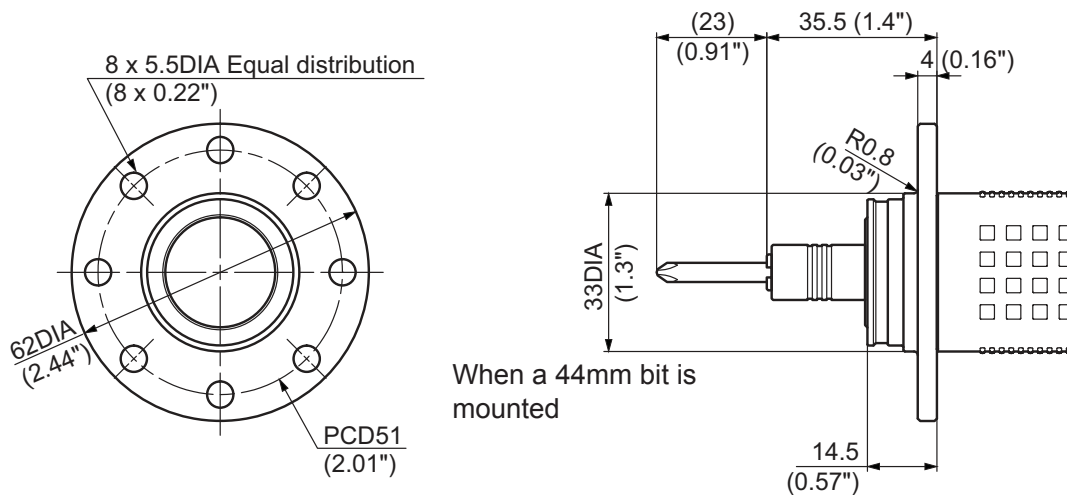

Sleeve

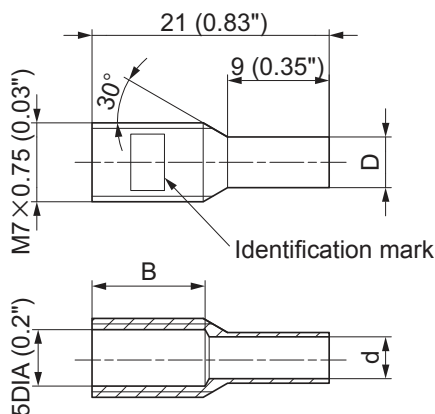

Unit: mm (in)

Sleeve	Identification mark	d	D	B
DLS2124	Pink	3.1 (0.12)	4.5 (0.18)	10 (0.39)
DLS2127	Black	3.7 (0.15)		
DLS2134	Blue	5.6 (0.22)	6.5 (0.26)	13 (0.51)