

INSTRUCTION MANUAL

Professional tool ELECTRIC SCREWDRIVER

delvo

Model: DLV30S/DLV45S/DLV70S AY Series

Product Operational Information

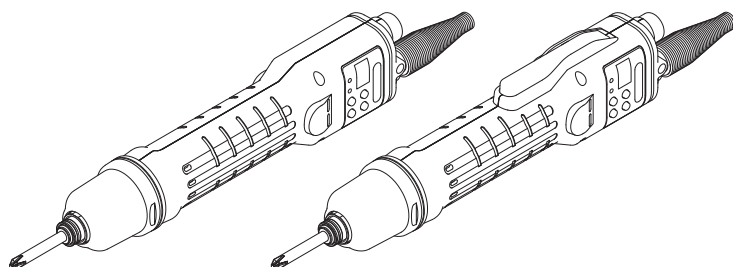

Indoor Use Only

Brushless Motor

ESD Protection

EN This instruction manual is written in English.
Instruction manuals in other languages can be downloaded from the URL below.

FR Ce manuel d'instructions est rédigé en anglais.
Les manuels d'instructions dans d'autres langues peuvent être téléchargés à partir de l'URL ci-dessous.

DE Diese Bedienungsanleitung ist auf Englisch verfasst.
Bedienungsanleitungen in anderen Sprachen können von der unten genannten URL heruntergeladen werden.

IT Il presente manuale di istruzioni è redatto in lingua inglese.
I manuali di istruzioni in altre lingue possono essere scaricati dal seguente URL.

ES Este manual de instrucciones está escrito en inglés.
En la dirección URL indicada abajo se pueden descargar los manuales de instrucciones en otros idiomas.

PT Este manual de instruções está escrito em inglês.
Pode descarregar os manuais de instruções nos outros idiomas a partir do URL indicado abaixo.

<http://www.nitto-kohki.co.jp/e/>

[Specifications]

Lever Start Model	DLV30S06L-AY	DLV30S12L-AY	DLV30S20L-AY	DLV45S06L-AY	DLV45S12L-AY	DLV70S06L-AY
Push to Start Model	DLV30S06P-AY	DLV30S12P-AY	DLV30S20P-AY	DLV45S06P-AY	DLV45S12P-AY	DLV70S06P-AY
Torque [Nm(Lb-in)]	Low torque spring: 0.4 to 1.6 (3.5 to 14.2)			2.0 to 4.5 (17.7 to 39.8)		3.8 to 7.0 (33.6 to 61.9)
	High torque spring: 1.2 to 3.0 (10.6 to 26.6)					
Free Speed [min ⁻¹]	160 to 650	300 to 1200	500 to 2000	160 to 650	300 to 1200	160 to 650

• Please refer to p. 5 for details.

- Please read manual carefully before you attempt to use your tool so that you may use it properly and safely.
- Keep the manual handy - so you can use it whenever necessary.

• Due to continuous product development/improvement the specifications and configurations in this document are subject to change without prior notice.

Manufactured by:

NITTO KOHKI CO., LTD.

9-4, Nakaikegami 2-chome, Ohta-ku, Tokyo, 146-8555, Japan
Tel : +81-3-3755-1111 Fax : +81-3-3753-8791

(Original Instructions)

TV07521-5 03/2020

Thank you very much for your purchase of this **NITTO KOHKI** product.

Before using your tool, please read this manual carefully so that you may use it properly to get the most out of it.

Please keep the manual handy - so you can use it whenever necessary.

Contents

Product Specific Safety Rules	1	10 Measuring the Screw Fastening Time	31
1 Application	2	Setting of the screw fastening time and rotation	
2 Checking Inside the Package	2	time	32
3 Part Names	3	11 Setting Functions	34
Motion setting unit (LED and buttons).....	4	Adjusting the screw fastening confirmation time.....	35
4 Specifications	5	Adjusting the NG signal output time.....	36
Torque and speed graph	7	Resetting the screw count.....	38
5 Preparation	9	Return the screw count one by one	39
Attaching a bit	9	Counting method of screw fastening count.....	40
Attaching the suspension bail	9	Bit Breaks function.....	40
Replacing a torque spring	10	Locking button operations.....	41
Attaching the Pistol Grip	11	12 Making Settings Using the Remote Controller	
Notes on attaching a commercially available fixing		42
jig	12	Switching data receiving mode	42
6 Basic Operation	13	Receiving data from the remote controller	43
Start	13	13 Using External Signals	44
Changeover switch	14	Specifications of external signal connector	44
Start and stop.....	15	External signal specifications.....	45
Screw tightening	16	Connection example of I/O signal	46
Adjusting the output torque	17	Using the workpiece signal	49
7 Basic Settings.....	18	Link function.....	55
Operation mode	18	Forced stop signal.....	59
Motion settings list	18	Changing the channel with an external signal	60
Function settings list	19	14 Appendix.....	61
Time display.....	19	Troubleshooting	61
NG display	20	Maintenance and inspection	63
Initialization of settings.....	21	Separately-sold products	65
8 Changing Channels	22	External dimensions.....	66
Channel setting mode	22	Glossary.....	67
Checking the channel	23	Index	69
9 Motion Setting.....	24	Setting memo.....	70
Switching the motion setting mode	24		
Initializing the motion setting.....	24		
Setting the screw count.....	25		
Setting the speed level and time.....	26		
Setting auto reverse mode.....	28		

Product Specific Safety Rules

⚠ WARNING

- **Use the dedicated power supply at all times.**
This tool requires a dedicated power supply provided by our company. Using other power supplies could result in a fire or accident.
- **Do not look directly into the LED (light-emitting part) from close up.**
Powerful LED light could damage your eyes. Also, do not point the LED (light-emitting part) at people's or animals' eyes.

⚠ CAUTION

- **Do not apply shock (such as dropping) or excessive load to the motion setting unit (LED or button).**
Doing so could cause a failure.
- **This tool is not an impact type electric screwdriver. Do not tighten twice (extra tightening). Also, it cannot be used for screw tightening of such things as wood or drywall.**
Depending on fastening conditions, screws may become loose.
Improper impacts could decrease product life or cause product failure.
- **Do not use the tool for anything other than screw tightening.**
It should not be used for tasks such as drilling or threading (such as a taper).
- **The relationship between the speed and the speed level is standard.**

About Unit Notation

This instruction manual is written using both SI units and the imperial measurement method (yards, pounds). Numeric values outside the () are the value in SI units, while those inside the () are the imperial measurement value.

Notation Example: Length 25.4 (1")

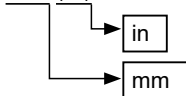

Weight: 0.45 (1)

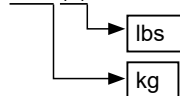

Torque: 1.13 (10)

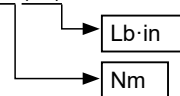

1 Application

This is a hand-held electric screwdriver used to tighten screws.

The tool is equipped with an environmentally-friendly brushless motor and can be set to handle various screw tightening.

You can use functions such as auto switching of the speed, display of the number of screws tightened, measuring of the screw fastening time, and interlocking with screw tightening to improve efficiency and quality of screw tightening as well as to prevent human error.

2 Checking Inside the Package

When you open the package box, check the content of the package and also check for any damage caused by incidents during transportation.

If a problem is found, consult with the store where you purchased the product.

Package content and list of accessories

DLV30S series		DLV45S series / DLV70S series	
Package content and accessories	Quantity	Package content and accessories	Quantity
Electric screwdriver (main unit)	1	Electric screwdriver (main unit)	1
Bit NK35 (No.2×7×75)	1	Bit NK35 (No.2×7×75)	1
Low Torque Spring	1	Suspension Bail	1
High Torque Spring*	1	Connection Cord DLW9073	1
Suspension Bail	1	Pistol Grip DLW2300ESD	1
Connection Cord DLW9073	1	Instruction Manual	2
Instruction Manual	2		

* The high torque spring is built inside the main unit at the factory default.

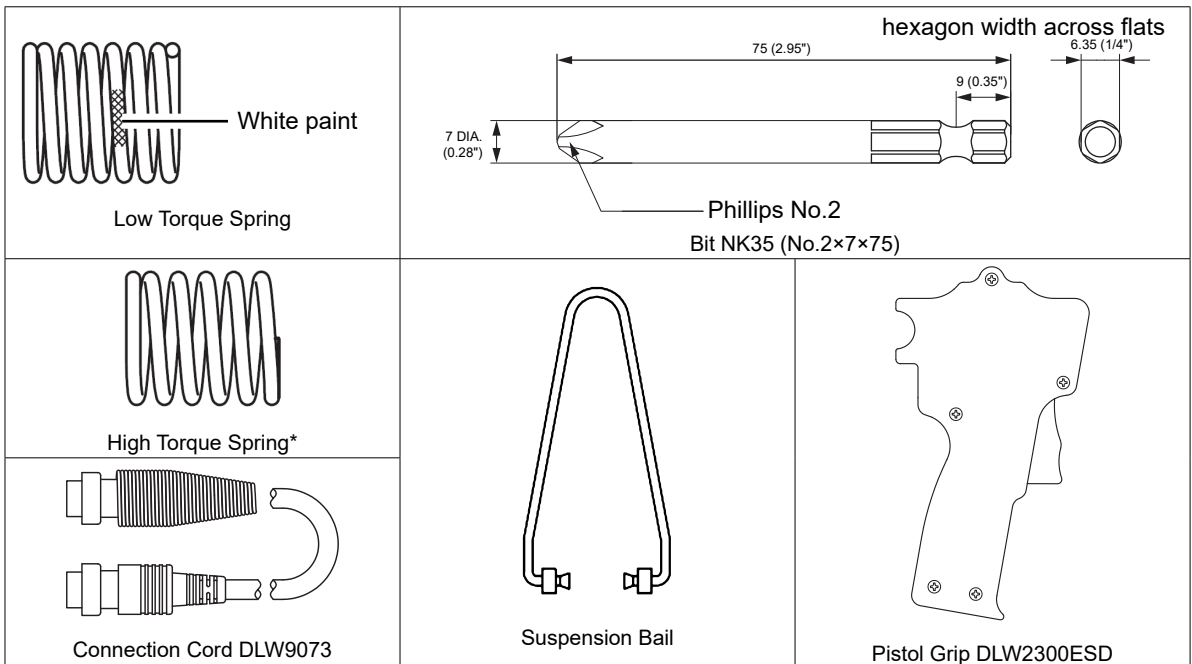

3 Part Names

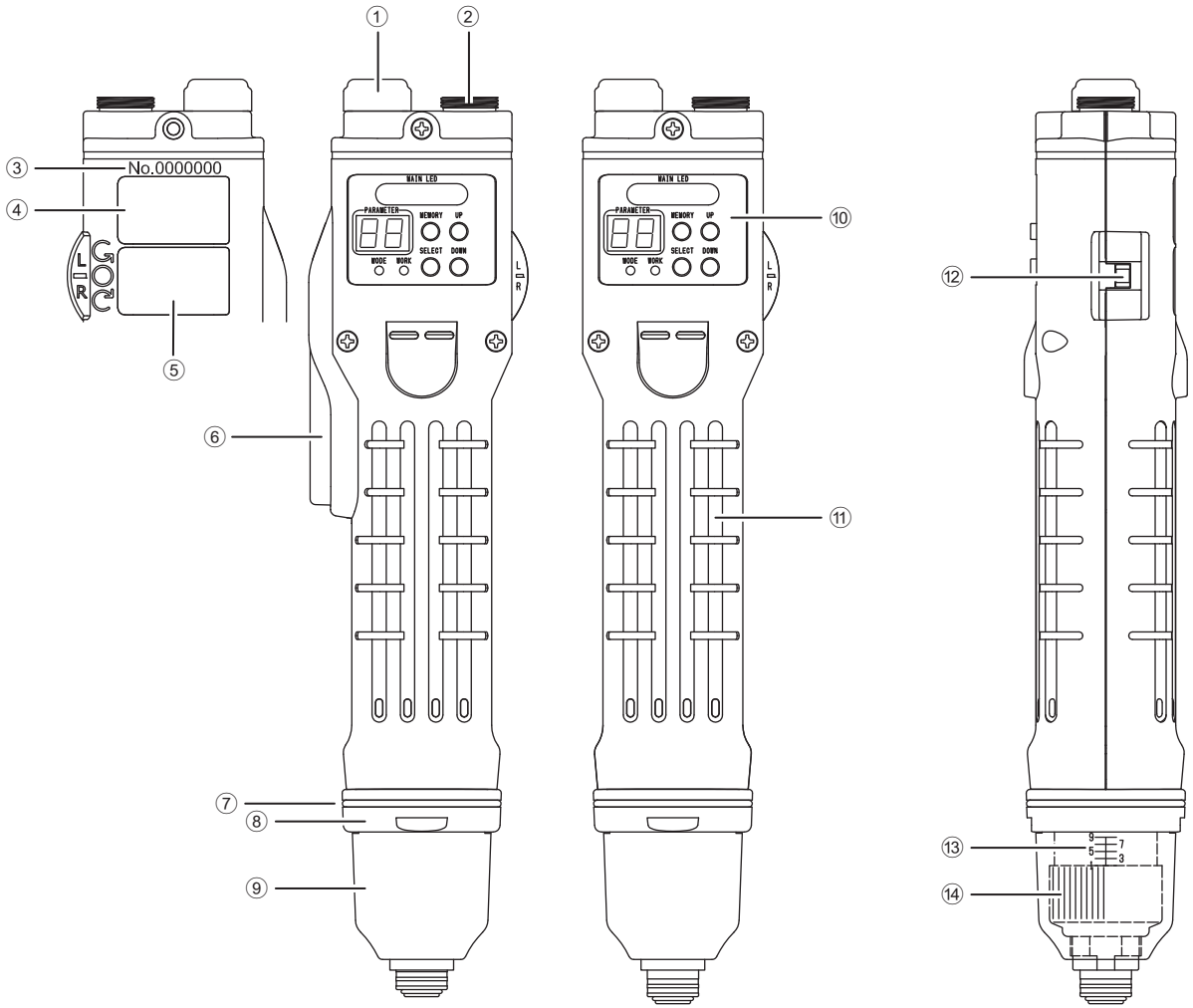

Lever start type

Push start type

- ① Connector Cap (covers the external signal connector; this can be removed)
- ② Power Supply Connector
- ③ Serial No
- ④ Rating Plate
- ⑤ Warning Plate
- ⑥ Lever Switch
- ⑦ Rubber Ring (the color varies by model)
- ⑧ Coupling
- ⑨ Torque Adjustment Ring Cover (the material varies by model)
- ⑩ Motion Setting Unit (p. 4)
- ⑪ Frame Handle (exterior resin part of main unit)
- ⑫ Changeover Switch
- ⑬ Torque Scale (standard)
- ⑭ Torque Adjustment Ring

Model		Rubber Ring	Torque adjustment ring cover
Lever start type	Push start type	Color	Material
DLV30S06L-AY	DLV30S06P-AY	Yellow	Resin
DLV30S12L-AY	DLV30S12P-AY	Blue	
DLV30S20L-AY	DLV30S20P-AY	Red	
DLV45S06L-AY	DLV45S06P-AY	Without rubber ring	Aluminum
DLV45S12L-AY	DLV45S12P-AY		
DLV70S06L-AY	DLV70S06P-AY		

- The torque adjustment ring cover prevents unexpected torque setting change. We recommend the cover be attached.

Motion setting unit (LED and buttons)

⚠ WARNING

- Do not look at the LED (light-emitting part) from close up. In addition, do not bring it near people's eyes. Powerful LED light could damage people's eyes.

⚠ CAUTION

- Do not apply a shock (such as dropping) or excessive load to the motion setting unit. Doing so could cause a failure.

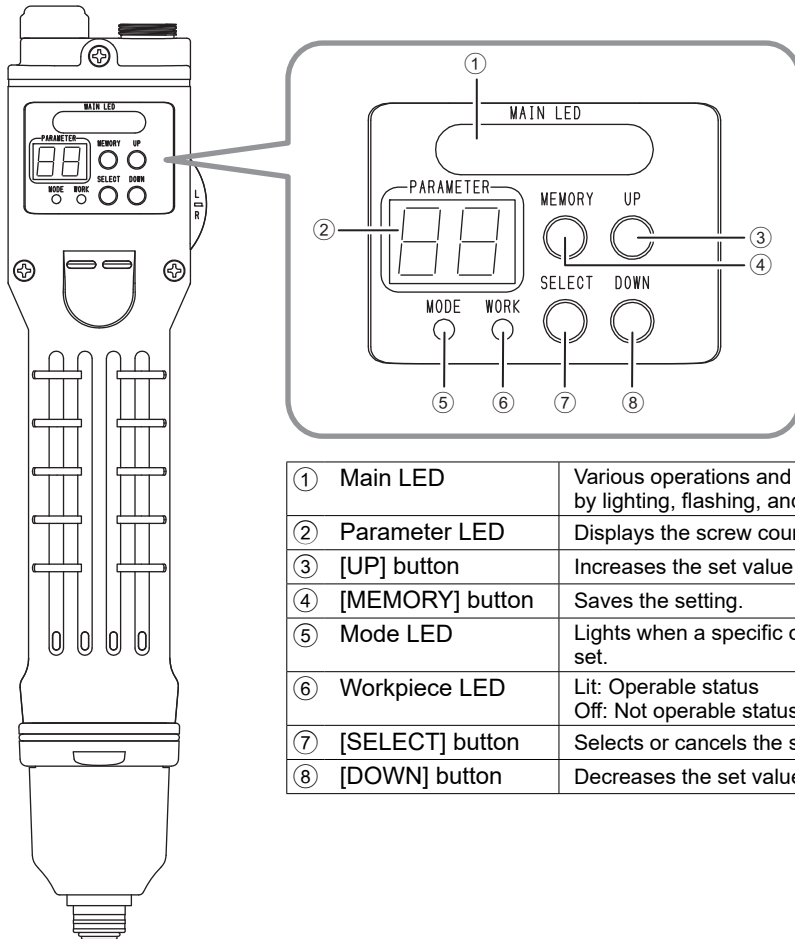

① Main LED	Various operations and settings are notified by lighting, flashing, and color.
② Parameter LED	Displays the screw count or set value.
③ [UP] button	Increases the set value number.
④ [MEMORY] button	Saves the setting.
⑤ Mode LED	Lights when a specific operation status is set.
⑥ Workpiece LED	Lit: Operable status Off: Not operable status
⑦ [SELECT] button	Selects or cancels the setting.
⑧ [DOWN] button	Decreases the set value number.

4 Specifications

⚠ CAUTION

- **The output torque is the value measured in combination with the output torque measurement device.**
When the output torque is measured by some other measuring device or combination, the value may be different.
- **The output torque and torque that occurs in screws do not match.**
Use a torque wrench to check the torque generated on screws.

Model	Lever Start	DLV30S06L-AY	DLV30S12L-AY	DLV30S20L-AY
	Push to Start	DLV30S06P-AY	DLV30S12P-AY	DLV30S20P-AY
Torque (Nm(Lb-in))	Low Torque Spring	0.4 to 1.6 (3.5 to 14.2)		
	High Torque Spring	1.2 to 3.0 (10.6 to 26.6)		
Free speed (for reference)	(min ⁻¹)	160 to 650	300 to 1200	500 to 2000
	Speed Level	Lv1 to Lv9 (• Lv1; Min. Speed • Lv9; Max. Speed • Speed reduces in stages)		
Screw Size (for reference)	Metric Thread (mm)	2.6 to 5.0		
	Inch Thread	#3 to #10		
	Tapping Screw (mm)	2.5 to 4.0		
Bit Type	NK35(HEX 6.35mm(1/4"))			
Mass (kg(lbs))	0.71(1.56)			
Input Voltage	40 V DC			
Dedicated Power Supply	DEA0151N-AZ or DEA0241N-AZ			DEA0241N-AZ
Power Consumption (W)	44			

Model	Lever Start	DLV45S06L-AY	DLV45S12L-AY	DLV70S06L-AY
	Push to Start	DLV45S06P-AY	DLV45S12P-AY	DLV70S06P-AY
Torque (Nm(Lb-in))	2.0 to 4.5 (17.7 to 39.8)			3.8 to 7.0 (33.6 to 61.9)
Free speed (for reference)	(min ⁻¹)	160 to 650	300 to 1200	160 to 650
	Speed Level	Lv1 to Lv9 (• Lv1; Min. Speed • Lv9; Max. Speed • Speed reduces in stages)		
Screw Size (for reference)	Metric Thread (mm)	4.5 to 6.0		5.0 to 8.0
	Inch Thread	#10 to #12		#10 to 5/16"
	Tapping Screw (mm)	4.0 to 5.0		4.5 to 6.0
Bit Type	NK35(HEX 6.35mm(1/4"))			
Mass (kg(lbs))	0.86(1.89) (Pistol Grip is included)			
Input Voltage	40 V DC			
Dedicated Power Supply	DEA0151N-AZ or DEA0241N-AZ		DEA0241N-AZ	
Power Consumption (W)	44			

DLV30S/45S/70S Series common specifications		
Duty Cycle		ON 0.5 sec / OFF 3.5 sec
Noise emission (dB) (According to EN60745)	LPA ^{*1}	75 (uncertainty :K=3dB)
	LWA ^{*2}	86
Vibration level (m/s ²) (According to EN60745)		Less than 2.5
ESD ^{*3} protection		Complied with IEC61340-5-1
Temperature Range (°C (°F))	Operating	-5 to +50 (+23 to +122)
	Storage	-20 to +70 (-4 to +158)
Relative Humidity		Free of Dew (include time of the Storage)
Operating Environment		less than 2000 m above sea level
Pollution Degree (According to IEC60664-1)		Pollution Degree 2
Over Voltage Category (According to IEC60664-1)		Over Voltage Category I

*1 LPA; A-weighted surface sound pressure level

*2 LWA; A-weighted sound power level

*3 ESD is the abbreviation of Electro-Static Discharge. It means the discharge of static electricity

Torque Measurement Device			
Electric Screw Driver	DLV30S Series	DLV45S Series	DLV70S Series
Torque Checker	DLT1673A	DLT1673A	DLT1973A
Bit Joint	DLW4360	DLW4360	DLW4000

Torque and speed graph

Torque scale and output torque (for reference)

⚠ CAUTION

- **The torque scale is for reference. The output torque range is not guaranteed.**
Make sure to measure torque.
- **Use the tool within the specified range.**
- **When the torque decreases, increase the torque based on the measured value.**

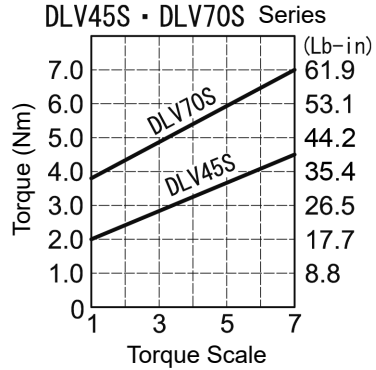
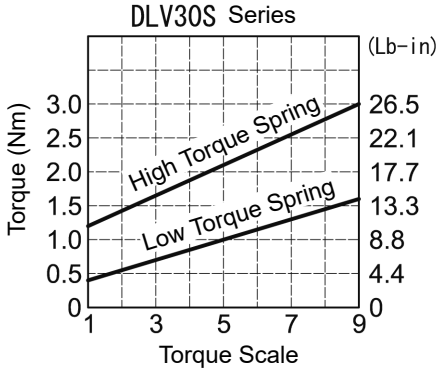

Range of use of speed level and output torque (for reference)

⚠ CAUTION

- **Range of use of speed level and output torque is for reference.**
The range of use changes depending on the fastening conditions (workpiece wherein a screw is tightened).
- **If a screw is tightened beyond the range of use, the parameter LED displays NG E8 (Motor-Lock) and the tool stops automatically.**
Decrease the output torque or lower the speed level.

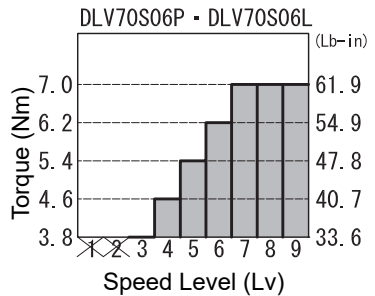
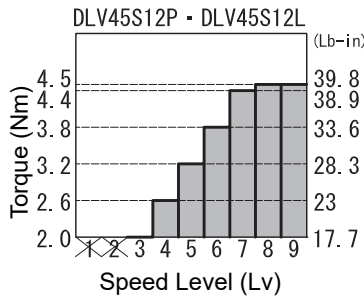
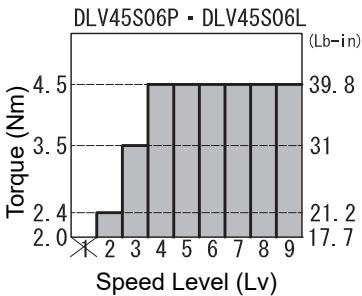
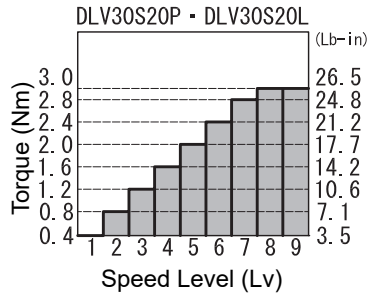
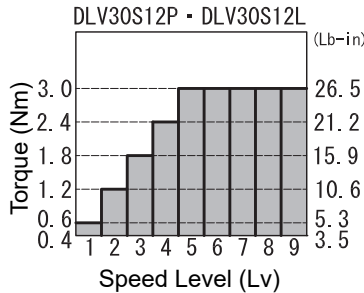
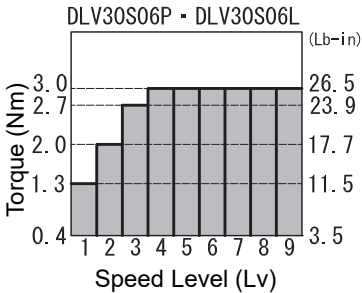

Speed level and speed (for reference)

⚠ CAUTION

- **The speed is for reference.**
The speed changes by the temperature of the tool, mechanical loss, and grease conditions. It could vary depending on differences in the tool itself.
- **When the speed is changed, the motor sound changes. This is not an error.**

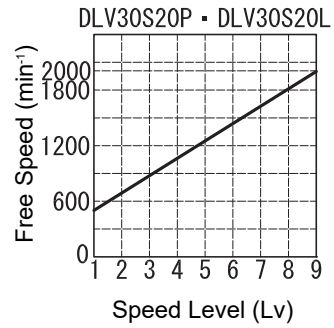
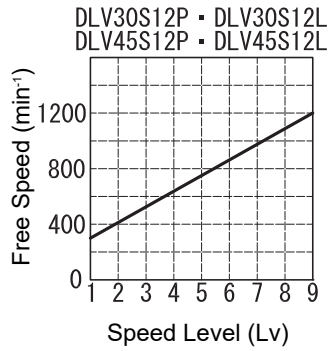
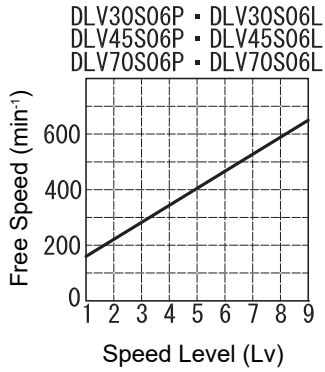

5 Preparation

Attaching a bit

⚠ WARNING

- Before attaching or detaching a bit, always turn OFF the power.

1 Insert a bit while pulling the sleeve

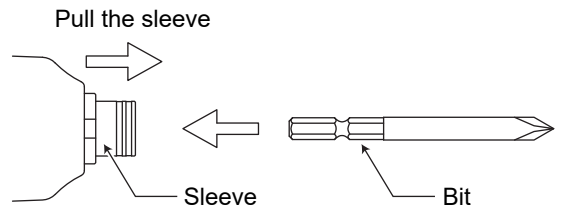

2 Release the sleeve and make sure the bit does not come off

To remove the bit, pull out the bit while pulling the sleeve.

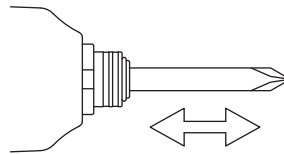

Attaching the suspension bail

⚠ CAUTION

- If the suspension bail is pulled forcefully, it may not return to original status. Use an appropriate strength necessary for attachment or removal.

1 Lightly pull both sides of the suspension bail and fit it into the hole

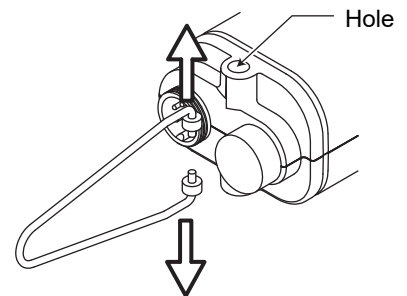

Replacing a torque spring

⚠ WARNING

- Before attaching or detaching the torque spring, always turn OFF the power.

⚠ CAUTION

- **The spring plate assembly must be oriented correctly.**
The ball goes into the recess of the torque adjustment ring. When it is attached in the opposite orientation, the torque adjustment ring easily gets loose. Also, when the torque adjustment ring is turned, there will be no clicking sound.
- **Recommended grease (separately sold)**
Idemitsu Kosan Co., Ltd.: Daphne Eponex SR No. 2
Showa Shell Sekiyu K.K.: Alvania Grease S2
Cosmo Oil Co., Ltd.: DYNAMAX No. 2

- 1** Turn the torque adjustment ring cover counterclockwise to remove

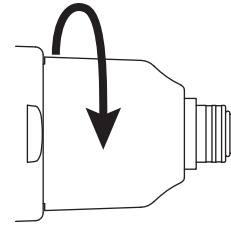

- 2** Turn the torque adjustment ring counterclockwise to remove

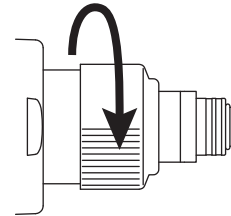

- 3** Remove the spring plate assembly
→ torque spring → plate, in that order

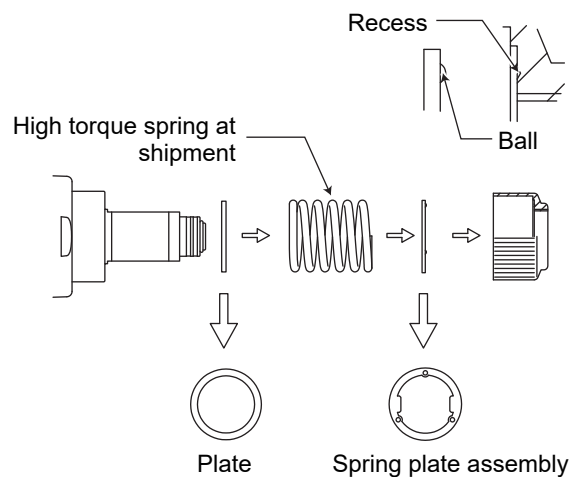

- 4** Apply grease to the torque spring

- 5** Replace the torque spring
To reattach, perform the order in reverse.

Attaching the Pistol Grip

⚠ WARNING

- Before attaching or detaching the Pistol Grip, always turn OFF the power.
- After fixing the Pistol Grip with the screw, check for looseness, slip, and displacement of the screw.

⚠ CAUTION

- Use care not to lose parts.

- 1 Match the rib of the Pistol Grip body A and the groove of the frame handle**
Match the semicircle cut-out of the Pistol Grip body A and the semicircle rib of the frame handle.
- 2 Attach the parts to the positions shown in the following figure**
- 3 Match the rib of the Pistol Grip body B and the groove of the frame handle**
Match the semicircle cut-out of the Pistol Grip body B and the semicircle rib of the frame handle.
- 4 Tighten the screws**

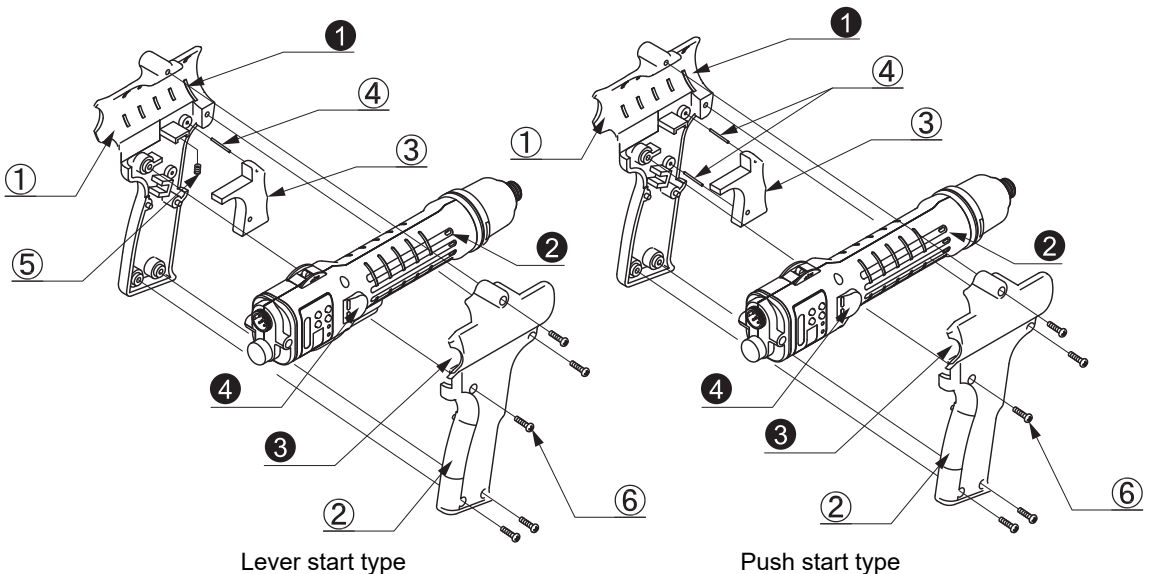

- ① Body A..... 1 piece
- ② Body B 1 piece
- ③ Trigger..... 1 piece
- ④ Pin..... 1 piece (2 pieces for push start type)
- ⑤ Spring..... 1 piece (lever start type only)
- ⑥ Screw 5 pieces
- ① Rib
- ② Groove
- ③ Semicircle cut-out
- ④ Semicircle rib

Notes on attaching a commercially available fixing jig

⚠ CAUTION

- Do not block the hole on the frame handle, as doing so could cause a failure due to heating.

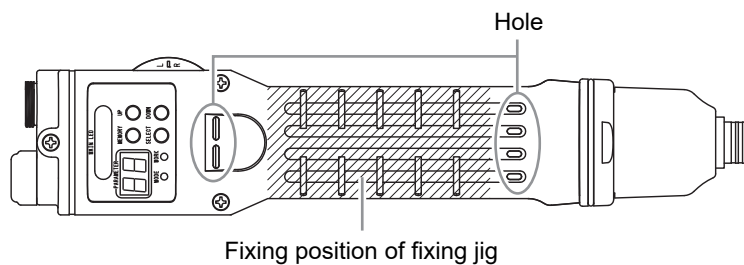

6 Basic Operation

Start

WARNING

- **Make sure to properly connect the connection plug of the power cord and power plug.**
- **Always make sure the tool is grounded.**
No grounding the tool could cause failure or electric shock at the time of electrical leakage.
If you are not sure about the grounding of the outlet, request an electrical contractor to check if it is grounded.
When an extension cord is used, use a 3-core cord that includes a ground wire.
- **Make sure to properly connect the connection cord.**
Other than supplying power, the connection cord is connected to the ground to eliminate static electricity.
The end metal section of the electric screwdriver is connected to the ground of the dedicated power supply via a 1 MΩ safety resistor inside the electric screwdriver.
Also, when the tool is used for a long time, the rotation part of the electric screwdriver becomes worn and the ability to remove static electricity decreases. Periodically request your sales agent to perform an overhaul on the tool.

1 Use the connection cord to connect the electric screwdriver and dedicated power supply

Check the orientation of the plug of the connection cord and insert all the way to the end.
Turn the sleeve clockwise and secure firmly.

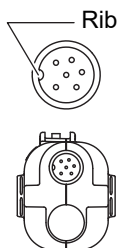
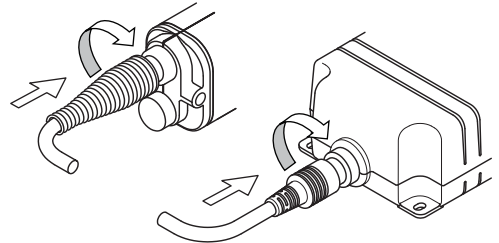

Power driver (male pin)

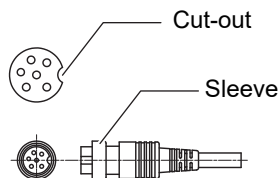

Connection Cord (female pin)

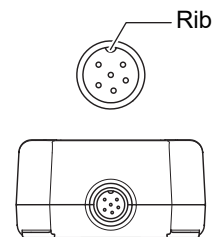

Dedicated power supply (male pin)

2 Insert the connection plug of the power cord to the dedicated power supply

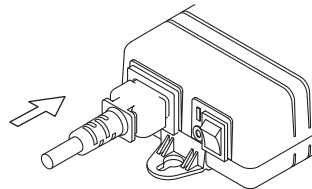

3 Insert the power plug into a grounded outlet (100 VAC - 240 VAC) to supply electricity

4 Turn ON (I) the power switch of the dedicated power supply

The power supply switch lights in green.
When the switch is turned OFF (O), the light goes out.

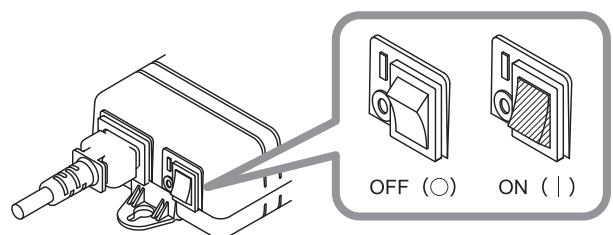

Screw fastening mode

The screw count is displayed on the parameter LED and the workpiece LED lights in green. When operation (rotation) is possible, this status is called “screw fastening mode.”

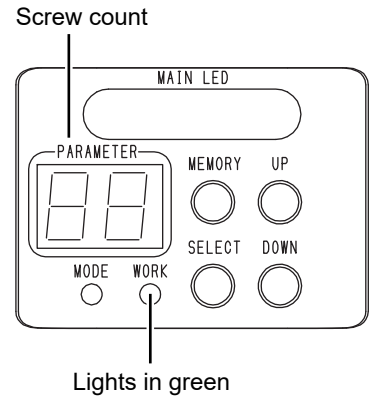

Changeover switch

⚠ CAUTION

- Do not operate the changeover switch while the tool is rotating. Doing so could cause a failure.
- When the tool is not used, set the switch to neutral position.
- Do not apply a shock (such as dropping) or excessive load to the changeover switch. Doing so could cause a failure.

By sliding the changeover switch, you can change the rotation direction of the electric screwdriver.

“ - ” means neutral. The electric screwdriver does not rotate.

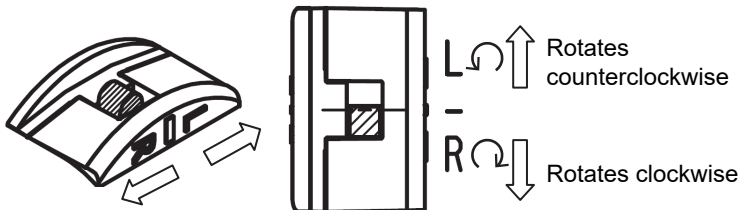

Start and stop

⚠ WARNING

- Never touch the bit while it is rotating.
- Do not direct the bit toward people or animals.

⚠ CAUTION

- Make sure to properly press the start switch.

Slide the changeover switch to the direction in which you want the tool to rotate and press the start switch to start. Releasing the start switch stops rotation.

Lever start type

When you press the lever switch, the bit rotates.

Releasing the lever switch stops rotation.

For the lever start type, the lever switch work as the start switch.

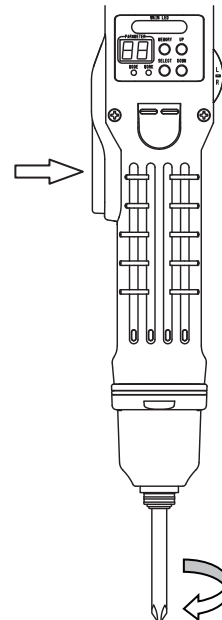

Push start type

The bit rotates when the electric screwdriver is pushed in the bit direction.

Releasing it stops rotation.

The push start type has a start switch inside the electric screwdriver.

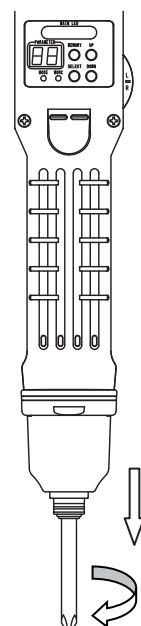

Screw tightening

⚠ WARNING

- Firmly hold the main body to avoid losing your grip.

⚠ CAUTION

- Properly apply the bit end to the screw head.
- Check that the bit is not worn.

- 1 Slide the changeover switch to the “R” side
- 2 Apply the bit end to the screw head and press the start switch
- 3 When the electric driver stops, release the start switch

When screw tightening is completed according to the setting

The electric screwdriver becomes torque-up status (the electric screwdriver arrives at the set torque and stops automatically with the click sound). The main LED lights in green, a buzzer sounds and the screw count on the parameter LED changes by one. (Increase/decrease of the screw count changes in accordance with the setting)

When screw tightening is not completed according to the setting

The main LED lights in red, a buzzer sounds and NG No. E1 to E9 flashes on the parameter LED. After that, the screw count is displayed. (The screw count does not change)

Screw tightening is completed up to the set number

The OK signal (the signal that is output when a series of work is completed) is output, the main LED lights in blue and a buzzer sounds. After that, the screw count returns to the initial set number.

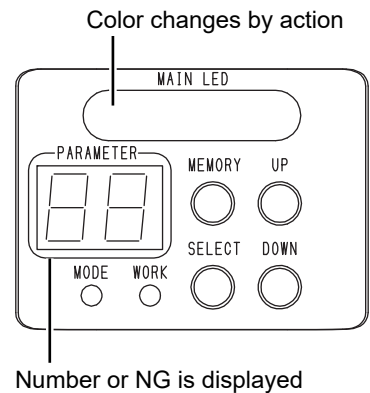

Adjusting the output torque

⚠ WARNING

- Before adjusting the output torque, always turn OFF the power.

⚠ CAUTION

- The torque scale is a standard. The output torque range is not guaranteed.

- 1 Turn the torque adjustment ring cover counterclockwise to remove it
- 2 To increase the output torque, turn the torque adjustment ring clockwise
To decrease the output torque, turn the torque adjustment ring counterclockwise

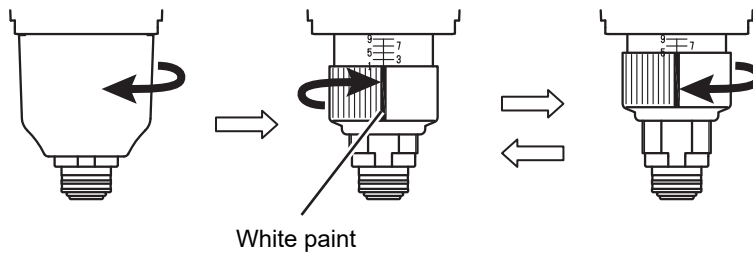

7 Basic Settings

Operation mode

The tool can be set to handle various screw tightening.

You can enter each mode from the screw fastening mode.

For details on operation and the operation of each function, see the reference page.

Mode	Operation	Operation to return to screw fastening mode	Reference
Change channel	Press and hold the [UP] button	Press and hold the [MEMORY] button or [SELECT] button	p. 22
Check set values	The changeover switch in neutral + Start switch ON	Start switch OFF	p. 23
Motion setting mode	Press and hold the [MEMORY] button + [UP] button	Press and hold the [MEMORY] button or [SELECT] button	p. 24
Function setting mode	Press and hold the [MEMORY] button + [SELECT] button	Press and hold the [MEMORY] button or [SELECT] button	p. 34
Lock/unlock keys	Press and hold the [MEMORY] button	Return automatically	p. 41
Screw count reset	Press and hold the [SELECT] button	Return automatically	p. 38
Count return mode	The changeover switch at the reverse side + press and hold the [DOWN] button	Return automatically, or press and hold the [SELECT] button, or operate the changeover switch	p. 39
Data receiving mode	Press and hold the [MEMORY] button + [DOWN] button.	Return automatically, or press and hold the [SELECT] button	p. 43

Motion settings list

CAUTION

- **Always record the set values. You can utilize “Setting memo” (p. 70).**
If the tool fails, all settings may be initialized. Also, settings may be initialized at the time of repair in order to check operation.
Please note that there is no function to output the set values to an outside device.

In screw fastening mode, press and hold the [MEMORY] button and [UP] button to enter the motion setting mode. For the operation procedure, see “9 Motion Setting” (p. 24).

The following settings are available.

No.	Function	Set values and operation	Default
1	Screw count	1 - 99 screws	1
2	Speed level at start	Level 1 - 9 (Parameter LED display is L1, L2...L9)	L9
3	Rotation time at start	0 sec.: 1st stage rotation setting is OFF / 0.01 - 0.99 sec.: 0.01 sec. intervals / 1.0 - 9.9 sec.: 0.1 sec. intervals	0
4	Speed level at middle	Level 1 - 9 (Parameter LED display is L1, L2...L9)	L9
5	Rotation time at middle	0 sec.: 2nd stage rotation setting is OFF / 0.01 - 0.99 sec.: 0.01 sec. intervals / 1.0 - 9.9 sec.: 0.1 sec. intervals	0
6	Speed level at finish	Level 1 - 9 (Parameter LED display is L1, L2...L9)	L9
7	Lower limit of screw fastening time	0 sec.: Lower limit of screw fastening time is OFF / 0.01 - 0.99 sec.: 0.01 sec. intervals / 1.0 - 9.9 sec.: 0.1 sec. intervals	0
8	Upper limit of screw fastening time	0 sec.: Upper limit of screw fastening time is OFF / 0.01 - 0.99 sec.: 0.01 sec. intervals / 1.0 - 9.9 sec.: 0.1 sec. intervals	0
9	Auto reverse mode setting	0: OFF / 1: Reversal after torque-up / 2: Reversal after lower limit of screw fastening time	0
10	Reverse speed level	Level 1 - 9 (Parameter LED display is L1, L2...L9)	L9
11	Reverse rotation time	0 sec.: Reverse setting is OFF / 0.1 - 0.99 sec.: 0.01 sec. intervals / 1.0 - 9.9 sec.: 0.1 sec. intervals	0

Function settings list

⚠ CAUTION

- **Always record the set values. You can utilize "Setting memo" (p. 70).**

If the tool fails, all settings may be initialized. Also, settings may be initialized at the time of repair in order to check operation.





Please note that there is no function to output the set values to an outside device.

In screw fastening mode, press and hold the [MEMORY] button and [SELECT] button to enter the function setting mode. For the operation procedure, see "11 Setting Functions" (p. 34).

The following settings are available.

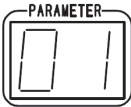

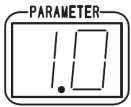
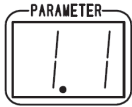



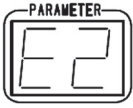

No.	Function	Set values and operation	Default	Reference
1	Workpiece signal	0: Do not input / 1: Input	0	p. 49
2	Workpiece setup time	0 sec.: OFF / 0.1- 9.9 sec.: 0.1 sec. intervals	0	p. 51
3	Start timing of workpiece setup NG	0: When workpiece is set / 1: When workpiece is set and the screwdriver rotates	0	p. 51
4	Screw fastening confirmation time	0 sec.: OFF / 0.1- 9.9 sec.: 0.1 sec. intervals	0	p. 35
5	OK signal output timing	0: When the set count ends / 1: When the set count ends and the workpiece is removed	0	p. 52
6	NG signal output time	0 sec.: OFF / 0.1- 9.9 sec.: 0.1 sec. intervals	0.1	p. 36
7	NG display	0: Do not continue / 1: Continue	0	p. 36
8	NG signal output selection	0: Output all NGs / 1: Output screwdriver NG / 2: Output workpiece setup NG	0	p. 54
9	Count return function	0: Do not use / 1: Use	0	p. 39
10	Count method	0: Count down / 1: Count up	0	p. 40
11	Bit Breaks function	0: Do not use / 1: Use	0	p. 40
12	Channel switching method	0: Inside screwdriver / 1: External signal	0	p. 60
13	Pin No. 7 output switching	0: Outputs channel switching signal / 1: LINK-OUT	0	p. 57
14	Pin No. 4 input switching	0: Forced stop signal / 1: LINK-IN	0	p. 57
15	Screw fastening completion sound setting	0: OFF / 1: Sounds beep for each screw	1	
16	OK sound setting	0: OFF / 1: Pi Pi Pi / 2: Pin Pon / 3: Do Re Mi / 4: Pi Po / 5: Pi-Pi Pi--	1	
17	Workpiece setup NG sound setting	0: OFF / 1: Bu Bu Bu / 2: Bu-Bi-- / 3: Do Si La / 4: Bu-- / 5: Bu-Bu Bu--	1	
18	Screwdriver NG sound setting	(Only NG display E7 for No. 17, NG sound other than E7 for No. 18)	1	
19	NG output setting during free rotation	0: Output NG / 1: Do not output NG ● With "Do not output NG", an upper/lower limit time judgment error is not output when rotation stopped without reaching the set torque.	0	p. 26

Time display

0.01 sec. increments	 0.01 sec.	 0.02 sec.	 0.99 sec.
0.1 sec. increments	 1.0 sec.	 1.1 sec.	 9.9 sec.

NG display

When NG operation occurs, the parameter LED displays a No. from E1 to E9 and the main LED lights in red. While the main LED lights in red, the electric screwdriver does not operate (rotate).

No.	Parameter LED	Details
E1		When rotation stopped before the lower limit of screw fastening time elapses (when torque reached the set torque or the start switch is pressed)
E2		When the screwdriver is rotating longer than the upper limit of screw fastening time
E3		When the operation time setting is as follows: <ul style="list-style-type: none"> ● Upper limit of screw fastening time < Lower limit of screw fastening time ● Lower limit of screw fastening time < Rotation time at start or middle
E4		In auto reverse mode setting, the torque reached the set torque and rotation stopped during reverse turning
E5		In auto reverse mode setting, rotation stopped when the start switch is released during reverse turning
E6		In auto reverse mode with the "Reverse after the lower limit of screw fastening time" setting, when the torque reached the set torque and rotation stopped before switching to reverse rotation
E7		When workpiece signal input "1: Input" is set, the workpiece signal is turned OFF (the workpiece is removed) during the period between when the workpiece setup NG starts and when the OK signal is output
E8		When the motor has insufficient power (Motor-Lock) * Increase the speed level or decrease the output torque. When it is not improved, the fastening condition is hard or the electric screwdriver has failed.
E9		When the board has failed and the setting conditions cannot be read

Initialization of settings

It is possible to initialize settings to the factory default.

Note that the security setting performed from the remote controller (sold separately) cannot be canceled. Also, the settings cannot be initialized while the security is set. Turn OFF the security setting and perform initialization.

⚠ CAUTION

- **When initialization is performed, all settings return to the default.**

For each motion setting channel, it is possible to use the function setting for initialization. If you do not remember settings, we recommend that the settings be initialized stepwise.

Initializing the motion setting (p. 24)

Initializing the function setting (p. 34)

- 1 Turn off the power of the electric screwdriver
- 2 While pressing the [MEMORY] button and [SELECT] button, turn on the power

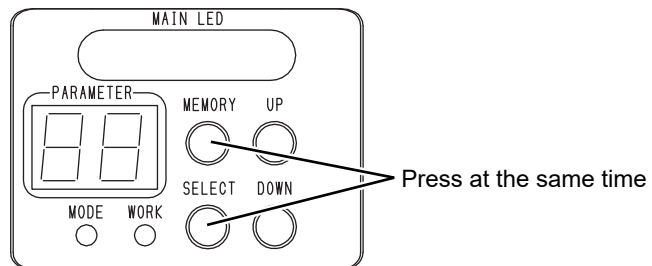

Each LED lights and a buzzer sounds informing you the completion of initialization.

8 Changing Channels

Channel setting mode

The folder where the “Motion settings list” (p. 18) is saved is called a “channel” and 8 channels can be used by switching.

This mode can be used when function No. 12 “Channel switching method” is set to “0: Inside screwdriver.” (p. 60)

1 In screw fastening mode, press and hold the [UP] button

The buzzer sounds, the main LED lights in red and the workpiece LED goes OFF.

The currently set channel No., between C1 and C8, is displayed on the parameter LED.

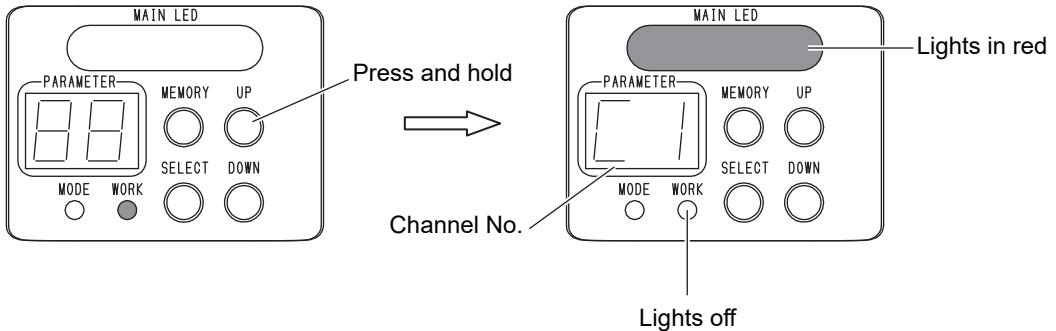

2 Use the [UP] button or [DOWN] button to select the channel No.

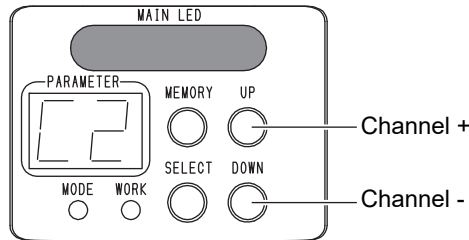

3 Press and hold the [MEMORY] button to change the channel

The main LED lights in purple and the mode returns to screw fastening mode.

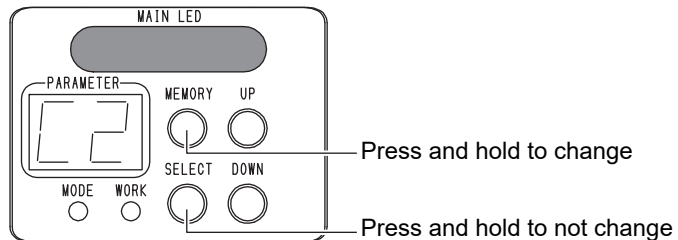

Checking the channel

While in screw fastening mode, you can check the current channel and set a value.

- 1 Slide the changeover switch to the “-” (neutral) side

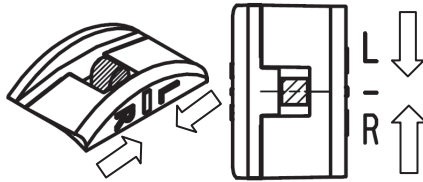

- 2 Press the start switch

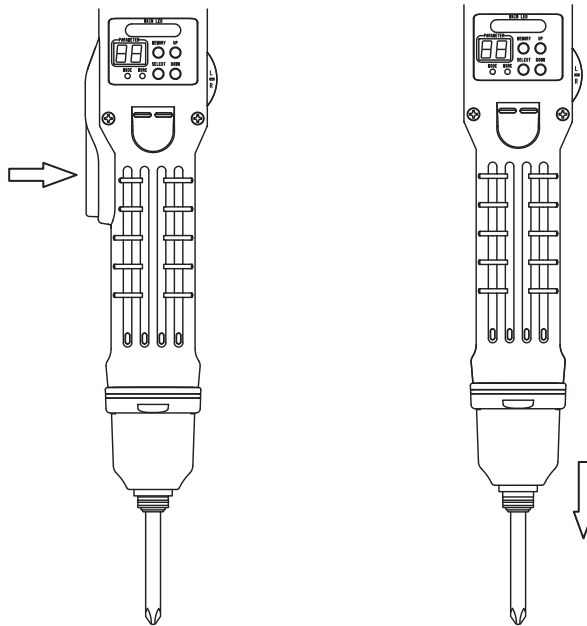

Lever start type

Push start type

While pressing the start switch, the channel No. and set value are displayed in order on the parameter LED.

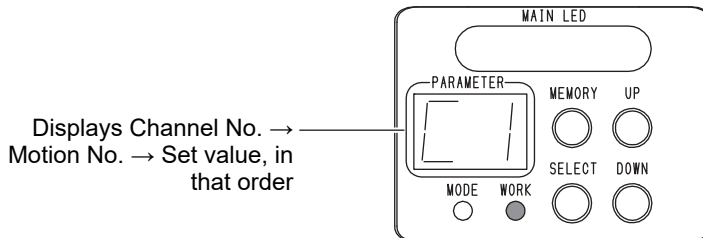

- 3 Release the start switch

The mode returns to screw fastening mode.

9 Motion Setting

Switching the motion setting mode

Set the electric screwdriver motion (rotation) for each channel.

- 1 In screw fastening mode, press and hold the [MEMORY] button and the [UP] button**
The buzzer sounds, the main LED lights in purple and the workpiece LED goes OFF.

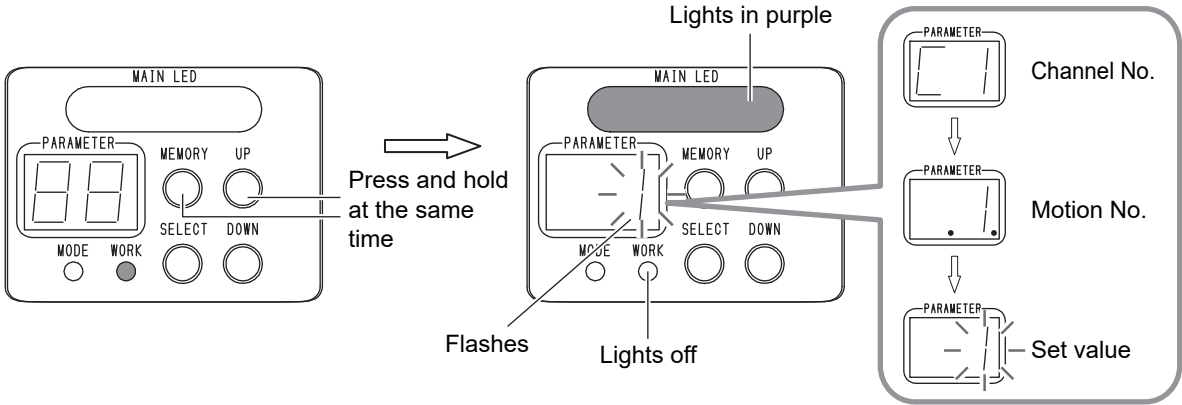

- 2 Use the [UP] or [DOWN] button to select a set value**
To check the set motion No., press the [MEMORY] button. (p. 18)
- 3 Press the [SELECT] button to select the next motion**
- 4 Press and hold the [MEMORY] button to save the setting**
The main LED flashes in blue and the mode returns to screw fastening mode.

Initializing the motion setting

Return the setting to the default. Once initialization is performed, you cannot restore the settings.

- 1 In motion setting mode, press and hold the [UP] button and [DOWN] button**

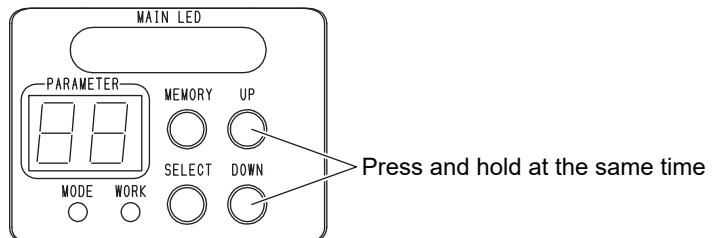

The set value is initialized.

Setting the screw count

- 1 In screw fastening mode, press and hold the [MEMORY] button and the [UP] button**
The buzzer sounds, the main LED lights in purple and the workpiece LED goes OFF.
The mode enters motion setting mode.
- 2 Use the [UP] button or [DOWN] button to set the screw count (1 to 99)**
Pressing and holding the button increases the count.
- 3 Press the [SELECT] button**
- 4 Press and hold the [MEMORY] button to save the setting**

Setting the speed level and time

You can change the speed during screw tightening. By combining low speed and high speed, work efficiency and quality can be improved.

CAUTION

- **When the speed difference is great, it may take time for the speed to be switched.**
Set this item after checking the actual rotation status.
- **If the set time is too short, the rotation may not be transmitted to the bit.**
Set this item after checking the actual rotation status.

1 In screw fastening mode, press and hold the [MEMORY] button and the [UP] button

The buzzer sounds, the main LED lights in purple and the workpiece LED goes OFF.
The mode enters motion setting mode.

2 Press the [SELECT] button to select the motion No.

The following settings are available.

Motion No.	Details	Setting
2	Changes the speed level at start	L1 - L9
3	Changes the rotation time at start	0 - 9.9 sec.
4	Changes the speed level at middle	L1 - L9
5	Changes the rotation time at middle	0 - 9.9 sec.
6	Changes the speed level at finish	L1 - L9
7	Changes the lower limit of screw fastening time	0 - 9.9 sec.
8	Changes the upper limit of screw fastening time	0 - 9.9 sec.

3 Use the [UP] button or [DOWN] button to set a value

4 Press and hold the [MEMORY] button to save the setting

Timing chart

When rotation stops before the lower limit of screw fastening time elapses, NG occurs and the parameter LED displays E1.

When rotation continues longer than the upper limit of screw fastening time, NG occurs and the parameter LED displays E2.

When the time settings are as shown below, NG occurs and the parameter LED displays E3.

Upper limit of screw fastening time < Lower limit of screw fastening time

Lower limit of screw fastening time < Rotation time at start or middle

Motion No.	Setting	Setting condition for variable setting: twice	Setting condition for variable setting: once	Setting condition for variable setting: none
2	Speed level at start	Optional	Optional	Optional
3	Rotation time at start	Optional	0 second or optional	0 sec.
4	Speed level at middle	Optional	Optional	Optional
5	Rotation time at middle	Optional	0 second or optional	0 sec.
6	Speed level at finish	Optional	Optional	Optional
7	Lower limit of screw fastening time	No. 3 + No. 5 or longer time	No. 3 or No. 5 or longer time	Optional
8	Upper limit of screw fastening time	No. 7 or longer time	No. 7 or longer time	No. 7 or longer time

CAUTION

- **When function No. 19 (NG output setting during free rotation) is set to "1: Do not output NG", if rotation stopped without reaching the set torque, an upper limit/lower limit judgment error of the screw fastening time is not output.**

Variable setting: twice

Speed

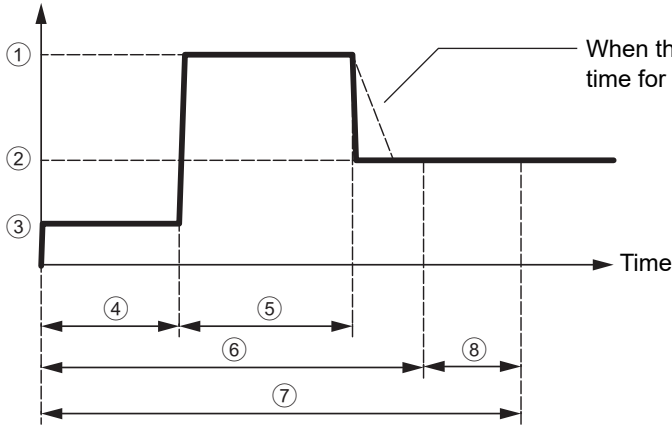

- ① Middle
- ② Finish
- ③ Start
- ④ Rotation time at start
- ⑤ Rotation time at middle
- ⑥ Lower limit of screw fastening time
- ⑦ Upper limit of screw fastening time
- ⑧ OK range

Variable setting: once

Speed

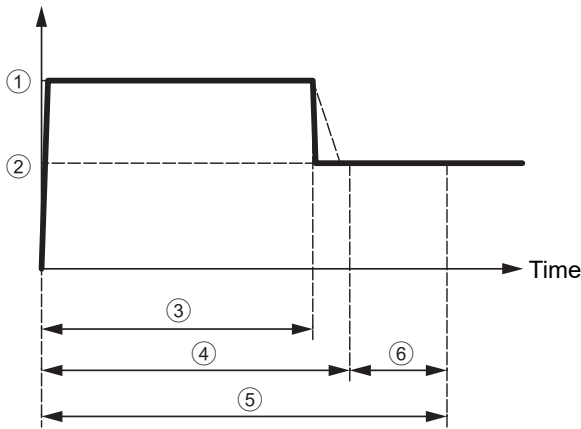

- ① Start or middle
- ② Finish
- ③ Rotation time at start or middle
- ④ Lower limit of screw fastening time
- ⑤ Upper limit of screw fastening time
- ⑥ OK range

* Set either the rotation time at start or middle to "0" second

Variable setting: none

Speed

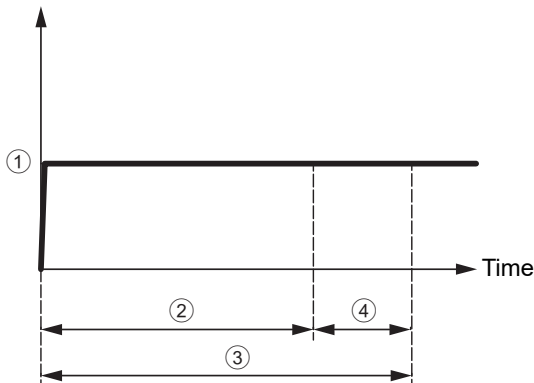

- ① Finish
- ② Lower limit of screw fastening time
- ③ Upper limit of screw fastening time
- ④ OK range

* Set both the rotation time at start or middle to "0" second

Setting auto reverse mode

Auto reverse mode means a motion to switch the electric screwdriver rotation direction automatically to the reverse. This mode is used when tightening a screw temporarily, intentionally loosening a screw (screws for terminal blocks, etc.) or checking a screw hole.

⚠ CAUTION

- When the setting is “Reverse after the lower limit of screw fastening time”, if the lower limit of screw fastening time is set to 0 sec. (OFF), the electric screwdriver does not start.
You must set a numeric value for the lower limit of screw fastening time.
- Depending on the fastening conditions, the screw may not be loosened when in reverse rotation.
Increase the reverse speed level. If the screw is still not loosened, the “Reverse after torque-up” function cannot be used. You must use “Reverse after the lower limit of screw fastening time.”
- If the reverse rotation time is too short, the rotation may not be transmitted to the bit.
Set this item after checking the actual rotation status.

- 1 Setting the speed level and time (p. 26)
- 2 In screw fastening mode, press and hold the [MEMORY] button and the [UP] button
The buzzer sounds, the main LED lights in purple and the workpiece LED goes OFF.
- 3 Press the [SELECT] button to select No. 9 (Auto reverse mode)

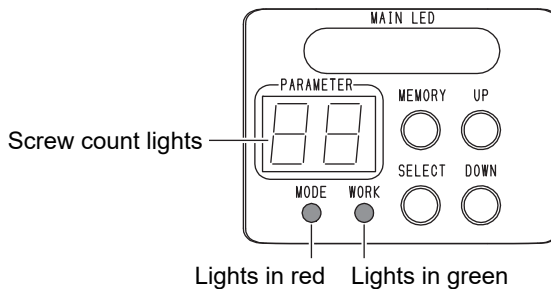

- 4 Press the [UP] button or [DOWN] button to select auto reverse mode

Setting	Details	Remarks
0	OFF	OFF regardless of the set value of motion No. 10 and 11
1	Reverse after torque-up	Screw tightening is operated with the No. 2 to 8 setting
2	Reverse after the lower limit of screw fastening time	Screw tightening is operated with the No. 2 to 7 setting

- 5 Press the [SELECT] button to select No. 10 (reverse speed level)
- 6 Press the [UP] button or [DOWN] button to select the speed level (1 - 9)
- 7 Press the [SELECT] button to select No. 11 (reverse rotation time)
- 8 Press the [UP] button or [DOWN] button to select the time (0 - 9.9 sec.)
- 9 Press and hold the [MEMORY] button to save the setting

Timing chart

When the torque reaches the set torque during reverse rotation in auto reverse mode, NG occurs and the parameter LED displays E4.

When the start switch is released during reverse rotation in auto reverse mode, NG occurs and the parameter LED displays E5.

When the setting is "Reverse after the lower limit of screw fastening time" in auto reverse mode, if the torque reaches the set torque during reverse rotation NG occurs and the parameter LED displays E6.

Motion No.	Setting	Setting condition: Reverse after torque-up	Setting condition for Reverse after lower limit of screw fastening time	Setting condition for Stop at lower limit of screw fastening time
9	Auto reverse mode setting	1	2	2
10	Reverse speed level	Optional	Optional	Optional
11	Reverse rotation time	Optional	Optional	0 sec.

Reverse after torque-up

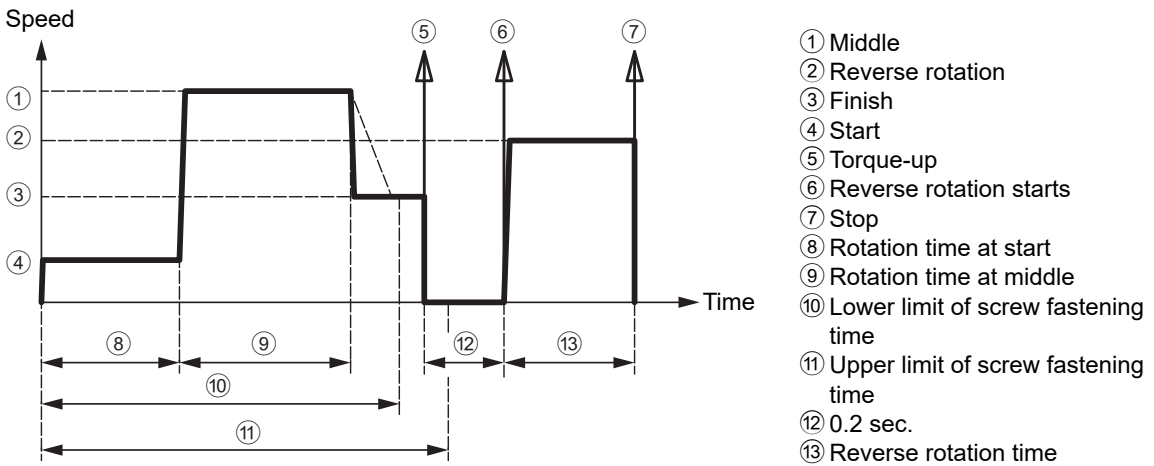

Reverse after the lower limit of screw fastening time

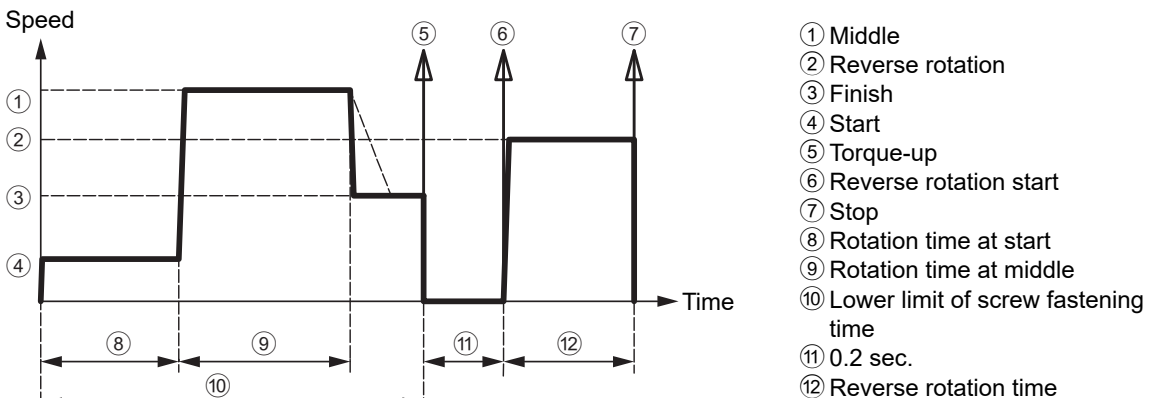

* Stop at the lower limit of screw fastening time

* About "Stop at reverse after the lower limit of screw fastening time", see the next page.

Stop at reverse after the lower limit of screw fastening time

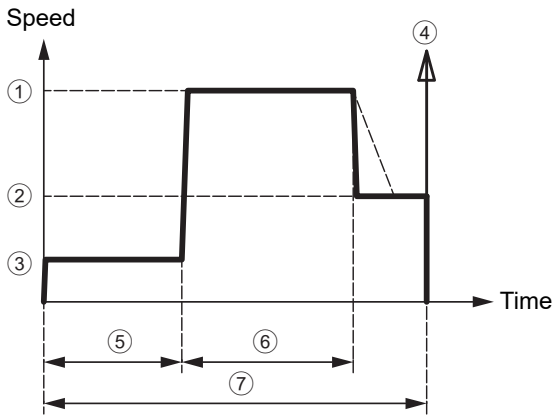

- ① Middle
- ② Finish
- ③ Start
- ④ Stop
- ⑤ Rotation time at start
- ⑥ Rotation time at middle
- ⑦ Lower limit of screw fastening time

10 Measuring the Screw Fastening Time

By setting the screw fastening time, it is possible to manage the length of screws to be used or screw fastening failure. This function measures the maximum and minimum values of the screw fastening time and by updating the value an optimum value can be found. Note that the screw length and electric screwdriver speed vary. Measure at least twice and make the setting.

1 In screw fastening mode, press and hold the [MEMORY] button and the [UP] button

The mode enters motion setting mode.

2 Press the [MEMORY] button and [SELECT] button at the same time

The buzzer sounds, the main LED lights in light blue, the parameter LED displays "--" and the mode enters screw fastening time measurement mode.

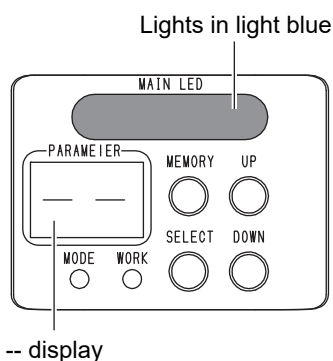

3 Tighten the screw several times

4 Use the [UP] button and [DOWN] button to check the maximum value and minimum value, respectively

While pressing the button, a value is displayed.

When [SELECT] button is pressed, the previous measurement result is canceled.

The duration of measurement is from when the electric screwdriver starts rotating to when the torque reaches the set torque.

If rotation stops without reaching the set torque, that measurement is not taken. (In case of reverse rotation, measurement is not taken)

When measurement is taken correctly, the parameter LED displays the measurement result.

By repeating screw tightening, the maximum and minimum measurement values are updated.

5 Press and hold the [MEMORY] button to save the measurement results

The minimum value is saved in the lower limit of screw fastening time (motion No. 7).

The maximum value is saved in the upper limit of screw fastening time (motion No. 8).

When saving is completed, the buzzer sounds, the main LED flashes in blue and the mode enters the motion setting mode.

If there is one or fewer measurement results, setting NG occurs (main LED flashes in red).

Setting of the screw fastening time and rotation time

Using the screw fastening time measurement mode, you can set the screw fastening time and each rotation time easily.

CAUTION

- **Periodically measure the screw fastening time.**

The speed has individual differences and it changes by impacts such as heating or mechanical loss. We recommend that the screw fastening time be measured periodically.

Example of setting: When screws are tightened in 3 stages of speed L1→L9→L1

1 Set the desired maximum speed level

In the motion setting mode, set the desired maximum speed level for the finish speed level (No. 6).

Turn OFF the rotation time at start and middle (No. 3 and 5) and turn OFF auto reverse mode (No. 9).

Motion No.	Setting
1	Optional
2	Optional
3	0
4	Optional
5	0
6	L9
7	Optional
8	Optional
9	0
10	Optional
11	Optional

2 Measure the screw fastening time minimum value of the maximum speed level used

Switch the mode to screw fastening time measurement mode, tighten the screw several times and then press the [DOWN] button to check the minimum value. (Example: 0.50 sec.)

Press and hold the [SELECT] button to cancel the measurement result. The mode is switched to the motion setting mode.

3 Based on the measured minimum value, set the rotation time at start and middle

Set the rotation time at start (No. 3) and rotation time at middle (No. 5).

For example, set 20% (0.10 sec.) of the measured minimum value as the rotation time at start and 60% (0.30 sec.) of the measured minimum value as the rotation time at middle.

Set the speed level (No. 2, 4 and 6) of start, middle and finish.

Motion No.	Setting
1	Optional
2	L1
3	10
4	L9
5	30
6	L1
7	Optional
8	Optional
9	0
10	Optional
11	Optional

4 Switch the mode to screw fastening time measurement mode and measure and set the maximum and minimum values of the screw fastening time

Tighten the screw several times and press and hold the [MEMORY] button to overwrite the measurement result. (Example: Minimum value 0.60 sec. / Maximum value 0.70 sec.)

When the rotation time of the finish is too long, cancel measuring and increase the rotation time of the middle (No. 5).

When the rotation time of the finish is short, cancel measuring and decrease the rotation time of the middle (No. 5).

The mode is switched to the motion setting mode.

5 Adjust the upper limit of screw fastening time value and lower limit value, respectively

For example, set the upper limit of screw fastening time to +10% (ex: 0.77 sec.) and the lower limit of screw fastening time to -10% (ex. 0.54 sec.).

When setting values, consider tolerances such as the screw length.

It is smooth to set the values after deciding the rotation time and level.

Motion No.	Setting
1	Optional
2	L1
3	10
4	L9
5	30
6	L1
7	54
8	77
9	0
10	Optional
11	Optional

11 Setting Functions

By setting various functions of electric driver, work quality can be improved. For the setting value of each function, see "Function settings list" (p. 19).

Function settings are applied to all channels. Functions cannot be assigned for each channel.

1 In screw fastening mode, press and hold the [MEMORY] button and [SELECT] button

The buzzer sounds, the main LED lights in green and the workpiece LED goes off.

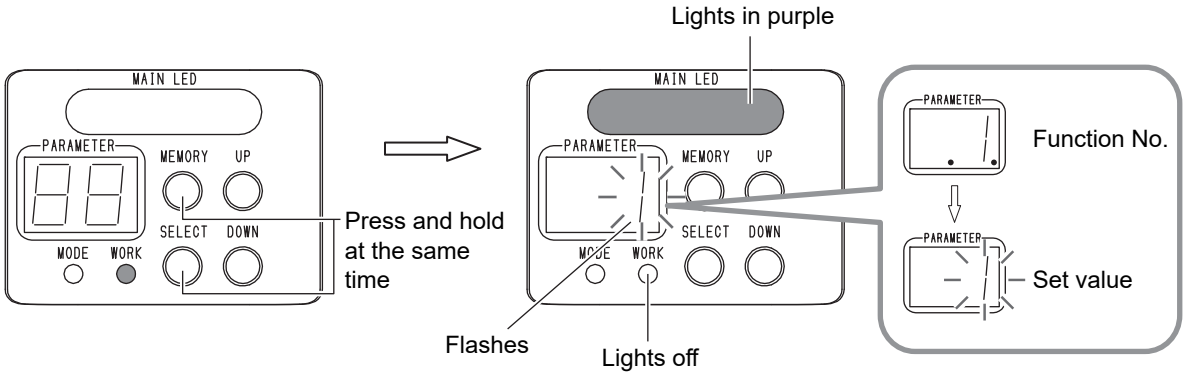

The mode enters function setting mode.

2 Press the [SELECT] button to select the function No.

3 Use the [UP] or [DOWN] button to select a set value

4 Press the [SELECT] button to select the next function

5 Press and hold the [MEMORY] button to save the setting

The main LED flashes in blue and the mode returns to screw fastening mode.

Initializing the function setting

A set value can be initialized by pressing and holding the [UP] button and [DOWN] button at the same time in function setting mode. Once initialization is done, you cannot restore the settings.

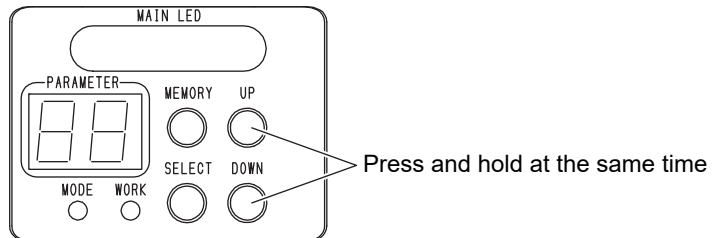

Adjusting the screw fastening confirmation time

During the screw fastening confirmation time, you can reverse screw tightening. Use this period for rework time or confirmation work time.

The main LED lights in green during the screw fastening confirmation time, and when the OK signal (output signal issued when a series of work is completed) is output after the screw fastening confirmation time, the main LED lights in blue.

Also, by pressing the [UP] button during the screw fastening confirmation time, the OK signal is output by skipping the screw fastening confirmation time.

- 1** In screw fastening mode, press and hold the [MEMORY] button and [SELECT] button
The mode enters function setting mode.
- 2** Press the [SELECT] button to select function No. 4
- 3** Use the [UP] button or [DOWN] button to change the screw fastening confirmation time (0 - 9.9 sec.)
- 4** Press the [SELECT] button to select function No. 5
- 5** Use the [UP] button or [DOWN] button to change the OK signal output timing to "0"
- 6** Press and hold the [MEMORY] button to save the setting

Timing chart

When function No. 1 (workpiece signal) is set to "1: Input", the timing chart is different. See "Adjusting the OK signal output" (p. 52).

When the [UP] button is not pressed

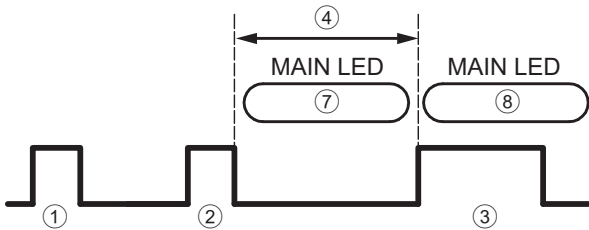

When the [UP] button is pressed

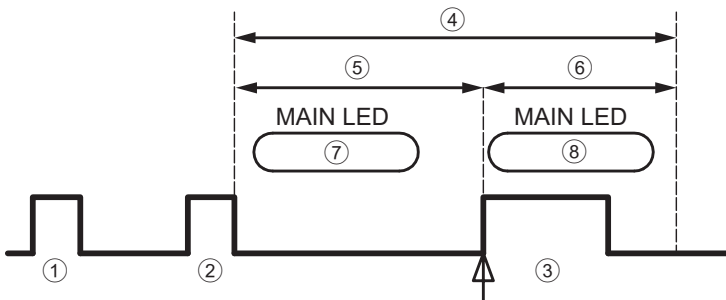

- ① Screw tightening
- ② Completion of screw tightening set count
- ③ OK signal 0.1 sec.
- ④ Screw fastening confirmation time
- ⑤ Time until the [UP] button is pressed
- ⑥ Time skipped
- ⑦ Lights in green
- ⑧ Lights in blue
- ⑨ Press the [UP] button

Adjusting the NG signal output time

You can check the NG content by setting the NG signal output time. When resuming work after NG work, if you have set the NG display to continue, you can understand that the work is interrupted by NG work.

When NG operation occurs, the parameter LED displays a No. from E1 to E9 and the main LED lights in red. During NG signal output time, the electric screwdriver does not operate.

By setting the NG display to "1: Continue", the parameter LED keeps displaying a value between E1 and E9. The main LED goes off. At this point, if you press the [UP] button, the mode changes to screw fastening mode.

* Only with E7, regardless of the set value, the NG signal is output until the workpiece signal is input again.

- 1 In screw fastening mode, press and hold the [MEMORY] button and [SELECT] button**
The mode enters function setting mode.
- 2 Press the [SELECT] button to select function No. 6**
- 3 Use the [UP] button or [DOWN] button to change the NG signal output time (0.1 - 9.9 sec.)**
- 4 Press the [SELECT] button to select function No. 7**
- 5 Use the [UP] button or [DOWN] button to change the NG display**
- 6 Press and hold the [MEMORY] button to save the setting**

Timing chart

When NG display is set to "0: Do not continue"

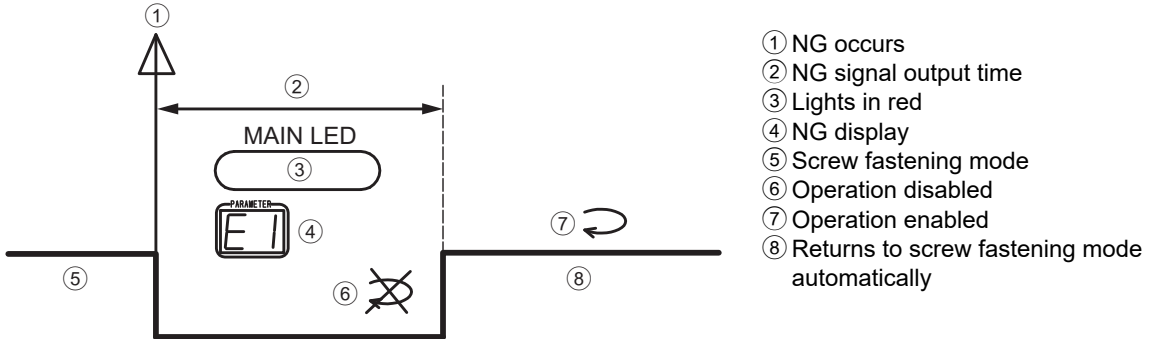

When NG display is set to "1: Continue"

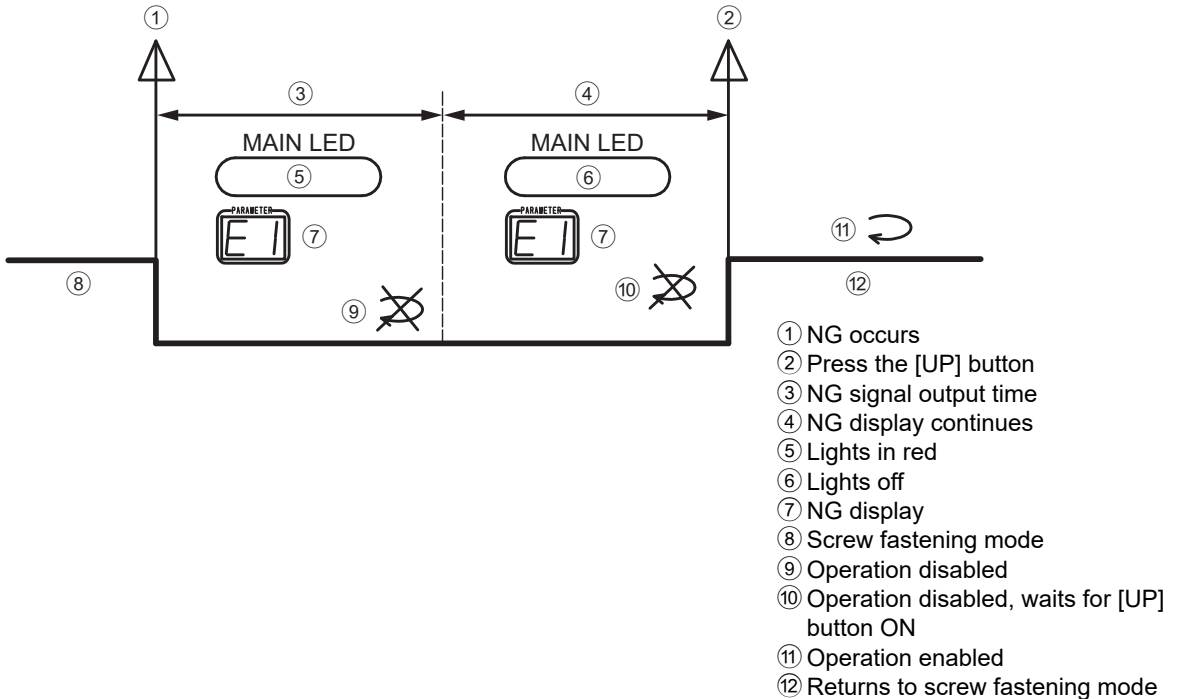

Resetting the screw count

You can reset the screw count during work.

- 1** In screw fastening mode, press and hold the [SELECT] button

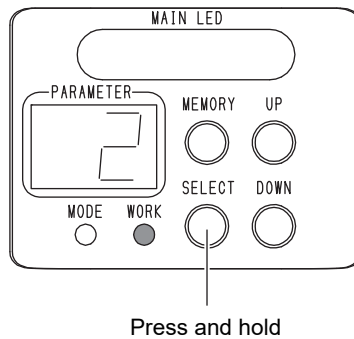

The screw count returns to the initial set value.
Reset is possible during the screw fastening confirmation time.

Return the screw count one by one

You can return the screw count one by one in the middle of work. This function is called the count return function. You can return the screw count one by one during the screw fastening confirmation time.

- 1 In screw fastening mode, press and hold the [MEMORY] button and [SELECT] button**
The mode enters function setting mode.
- 2 Press the [SELECT] button to select the function No. 9**
- 3 Use the [UP] button or [DOWN] button to change the setting to “1: Use”**
- 4 Press and hold the [MEMORY] button to save the setting**
- 5 Slide the changeover switch to the “L” side**

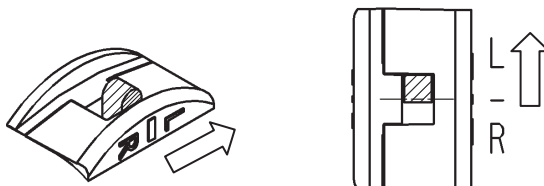

- 6 Press the [DOWN] button**
The buzzer sounds, the LED lights in blue and the workpiece LED goes off.

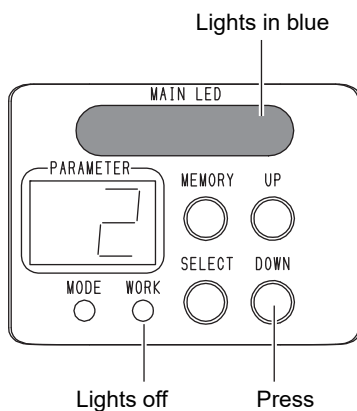

The mode returns to count return mode.

- 7 Press the start switch to rotate the electric screwdriver**
The screw count returns by one screw and the mode returns to screw fastening mode.
- 8 When you wish to return one more screw, repeat from Step 5**
To exit the count return mode, slide the changeover switch to the R side or press and hold the [SELECT] button. When no screw has been tightened, or “0: Do not use” was set in Step 3, count return cannot be performed.

Counting method of screw fastening count

You can change the counting method of the screw count.

- 1 In screw fastening mode, press and hold the [MEMORY] button and [SELECT] button**
The mode enters function setting mode.
- 2 Press the [SELECT] button to select function No. 10**
- 3 Use the [UP] button or [DOWN] button to select the counting method**

Setting		Setting details
0	Count down	Counts by decrementing the screw count to 0 from the set value
1	Count up	Counts by incrementing the screw count from 0 to the set value

- 4 Press and hold the [MEMORY] button to save the setting**

Bit Breaks function

The function that inserts a break when the start switch is released is called the Bit Breaks function.

Bit Breaks has the following advantages and disadvantages.

Advantages	Disadvantages
You can rotate the screw little by little	Break hold time of 0.2 sec. occurs
Prevents screw tightening relying on familiarity or instinct of workers Prevent screw tightening during inertial rotation	When a screw is sucked at the end of the bit by air or a magnet, the screws falls down due to break impact
Prevents accidents during inertial rotation	Impact occurs each time the start switch is released

- 1 In screw fastening mode, press and hold the [MEMORY] button and [SELECT] button**
The mode enters function setting mode.
- 2 Press the [SELECT] button to select function No. 11**
- 3 Use the [UP] button or [DOWN] button to select the breaking method**

Setting		Setting details
0	Do not use	When the start switch is released, the bit rotates inertially
1	Use	When the start switch is released, a break is applied

- 4 Press and hold the [MEMORY] button to save the setting**

Locking button operations

To prevent careless incorrect operation, you can lock button operations (Key lock).

1 In screw fastening mode, press and hold the [MEMORY] button

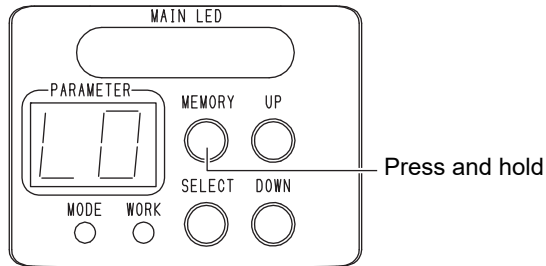

The parameter LED displays "LO" and the keys are locked.

2 To unlock the keys, press and hold the [MEMORY] button again

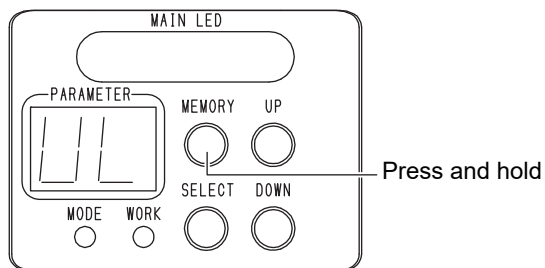

The parameter LED displays "UL" and the keys are unlocked.

While keys are locked, the following functions are valid.

- Count return function
- Data receiving mode
- [UP] button during screw fastening confirmation time
- [UP] button during continuous NG display

When using the remote controller (sold separately), you can lock/unlock keys remotely. In that case, the keys cannot be unlocked from the electric screwdriver side. This function can prevent settings being changed by people other than the remote controller administrator.

12 Making Settings Using the Remote Controller

The remote controller (sold separately) can be used to easily change settings of the electric screwdriver from a distance.

When you use the remote controller, you can change the settings of multiple electric screwdrivers while checking on the LCD. Also, some functions can only be set from the remote controller.

For details on the remote controller, see “Separately-sold products” (p. 65).

⚠ CAUTION

- Function No. 19 (NG output setting during free rotation) cannot be set with the remote controller.

Switching data receiving mode

- 1 In screw fastening mode, press and hold the [MEMORY] button and [DOWN] button

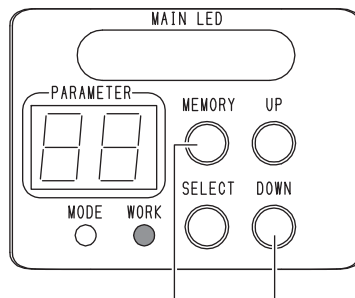

Press and hold at the same time

The buzzer sounds, the main LED lights in yellow and the workpiece LED goes off. Data reception from the remote controller is awaited.

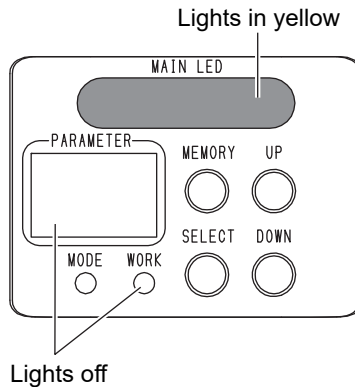

Lights in yellow

Lights off

Pressing and holding the [SELECT] button cancels data receiving mode.

Receiving data from the remote controller

When data is received from the remote controller, the main LED lights in blue.

When reception is successful, the main LED flashes in blue and the mode returns to screw fastening mode.

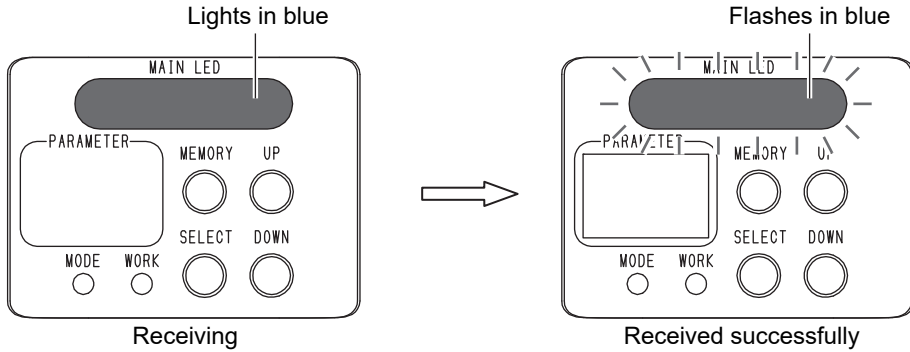

When reception fails, the main LED lights in yellow again to wait for data reception again.

For the usage and functions of the remote controller, see the instruction manual for the remote controller.

13 Using External Signals

You can input or output external signals via an external signal connector. A signal cable inserted into the external signal connector is sold separately. (p. 65)

⚠ CAUTION

- There is no internal power supply. Supply power (24 VDC) from outside.
- Before connecting the wire for the external signal, always turn OFF the power.

Specifications of external signal connector

Pin No.	Signal cable (sold separately) Wiring color	Signal	I/O
1	Red	+24 VDC power (supplied from outside)	
2	White	Workpiece signal	Input
3	Green	Reset signal	Input
4	Yellow	LINK-IN	Input
		Forced stop signal	
5	Brown	OK signal	Output
6	Blue	NG signal	Output
7	Gray	LINK-OUT	Output
		Channel switching signal	
8	Orange	Torque-up (count) signal	Output
9	Peach	Channel A	Input
10	Purple	Channel B	Input
11	Yellow-green	Channel C	Input
12	Black	0 VDC	

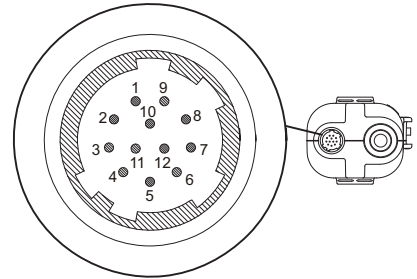

Attaching the signal cable

The external signal connector is HR10A-10R-12PC from Hirose Electric Co., Ltd. If a commercially available signal cable is connected, use a connection that can be connected using the above external signal connector.

1 Remove the connector cap

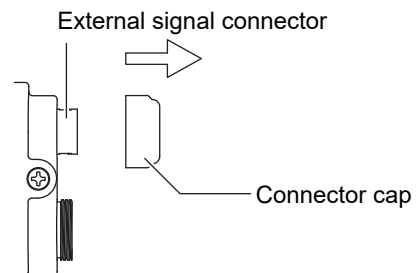

2 Check the direction of connector insertion

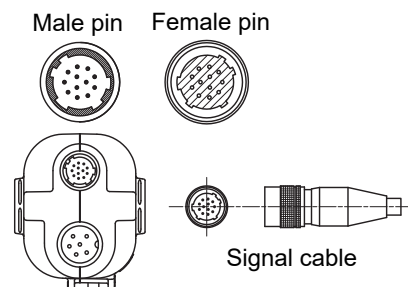

3 Attach the signal cable

When removing the cable, pull the sleeve and then pull out the signal cable.

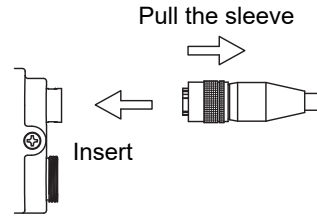

External signal specifications

I/O circuit

⚠ CAUTION

- There is no internal power supply. Supply power (24 VDC) from outside.

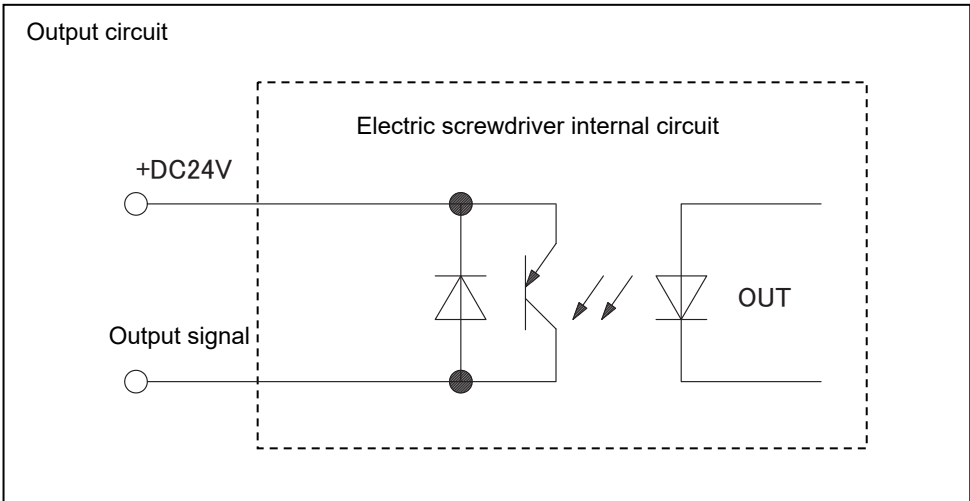
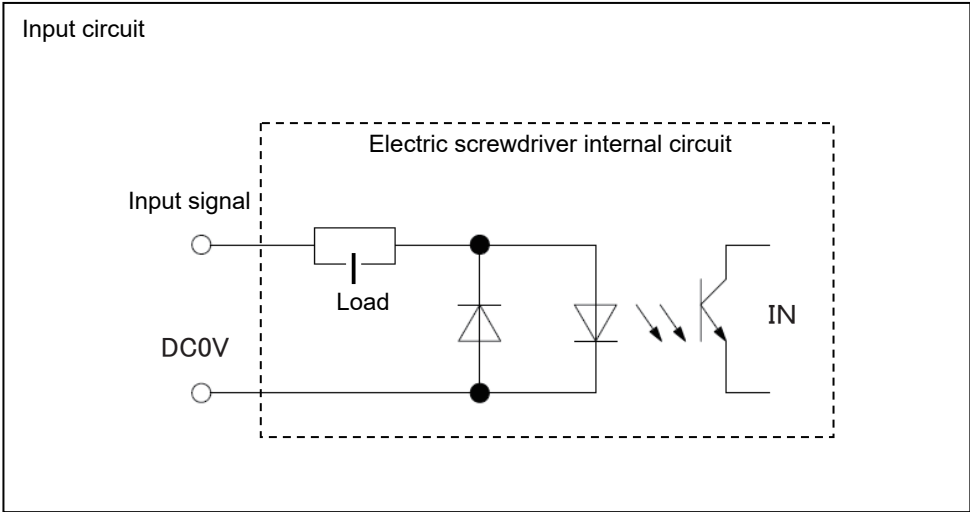

I/O signal specifications

Input signal	Photocoupler input 24 VDC 5 mA per input
Output signal	PNP open collector 24 VDC Max. 30 mA per output

Connection example of I/O signal

WARNING

- Before connecting the wire for the external signal, always turn OFF the power.

CAUTION

- **The illustration is a connection example.**
Components such as resistance are omitted.
Add resistance, etc. according to the electronic parts to be used.
- **For connection, use thick wire as much as possible. (AWG20 or more is recommended)**
- **For connection of an external signal, use a commercially available terminal block.**
- **A 2-wire sensor cannot be used.**
A 2-wire sensor has a flow of fine current even while OFF, and could cause a malfunction.
- **For the sensor, use a PNP output type 3-wire sensor.**
- **Depending on the sensor installation environment, a malfunction could occur due to noise. Make sure to take sufficient noise measures such as setting up grounding.**
For details, read the instruction manual of the sensor to be used.



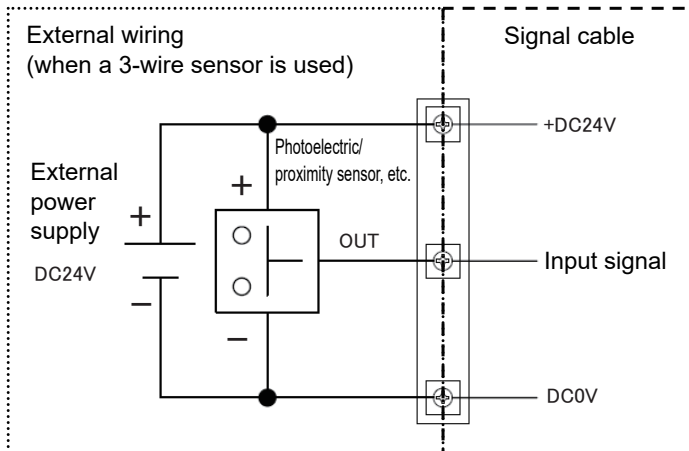
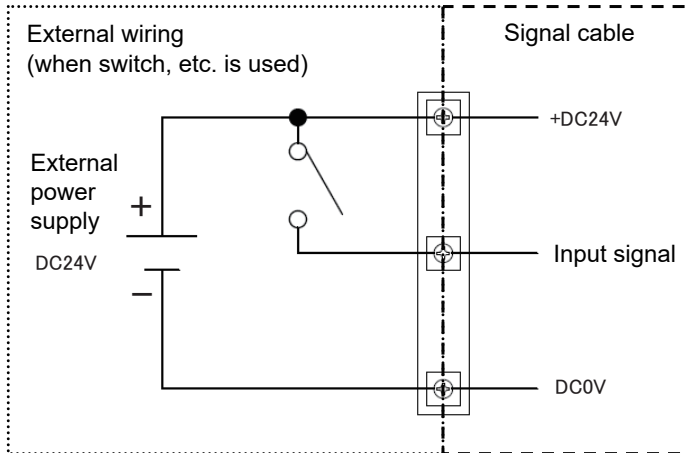

Connection example of input signal

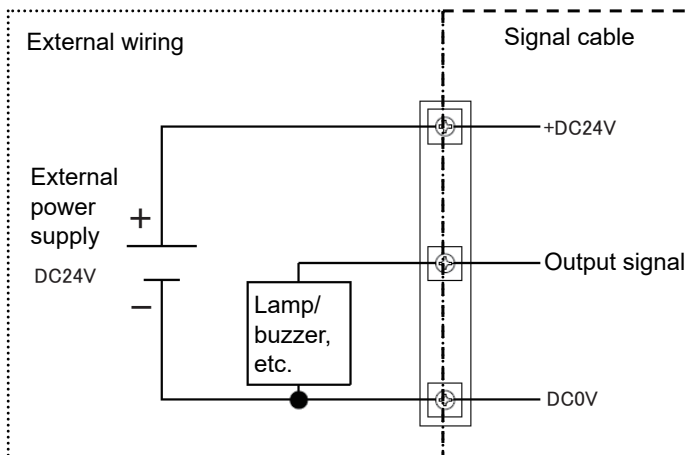



Connection example of output signal

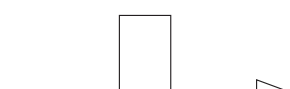

Timing of I/O signal

Input signal	Signal timing	Remarks
Workpiece signal	<p>ON</p>  <p>OFF</p>	While the input signal is ON, the workpiece signal is ON
Reset signal	<p>ON</p>  <p>OFF</p>	When the input signal is ON for 0.5 sec., reset is ON
LINK-IN	<p>ON</p>  <p>OFF</p>	Input from final screwdriver (see "Link function" (p. 55))
Forced stop signal	<p>ON</p>  <p>OFF</p>	While the input signal is ON, forced stop signal is ON
Channel A/B/C	<p>ON</p>  <p>OFF</p>	While the input signal is ON, channel A/B/C is ON

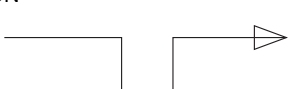
Output signal	Signal timing	Remarks
OK signal	<p>ON</p>  <p>OFF</p>	When the OK signal is output, ON for 0.1 sec. Or ON until the workpiece is removed (See "Adjusting the OK signal output" (p. 52))
NG signal	<p>ON</p>  <p>OFF</p>	ON during the NG signal output time (See "Selecting the NG signal output" (p. 54)) E7 is ON until the workpiece signal is input again
LINK-OUT	<p>ON</p>  <p>OFF</p>	Output for all screwdriver before the final screwdriver (see "Link function" (p. 55))

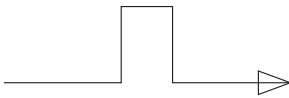
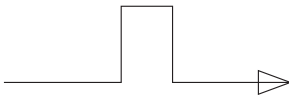
Output signal	Signal timing	Remarks
Channel switching signal	ON  OFF	ON for 0.1 sec. when the channel is switched
Count (torque-up) signal	ON  OFF	ON for 0.1 sec. at count (torque-up)

Using the workpiece signal

⚠ CAUTION

- **A 2-wire sensor cannot be used.**
A 2-wire sensor has a flow of fine current even while OFF, and could cause a malfunction.
- **For the sensor, use a PNP output type 3-wire sensor.**
- **Depending on the sensor installation environment, a malfunction could occur due to noise.**
Make sure to take sufficient noise measures such as setting up grounding. For details, read the instruction manual of the sensor to be used.

By using the workpiece signal, it is possible to prevent human errors and improve work quality.

1 Turn off the power of the electric screwdriver

2 Connect (wire) the I/O signal

Referring to the connection example of I/O signal (p. 46), connect the external power supply and sensor, etc.

Connected signal	Pin No.	Wiring color
+24 DC power	1	Red
Workpiece signal	2	White
0 VDC	12	Black

3 Turn ON the power of the electric screwdriver

4 Press and hold the [MEMORY] button and [SELECT] button

The mode enters function setting mode.

5 Use the [UP] or [DOWN] button to set the workpiece signal to “1: Input”

6 Press and hold the [MEMORY] button to save the setting

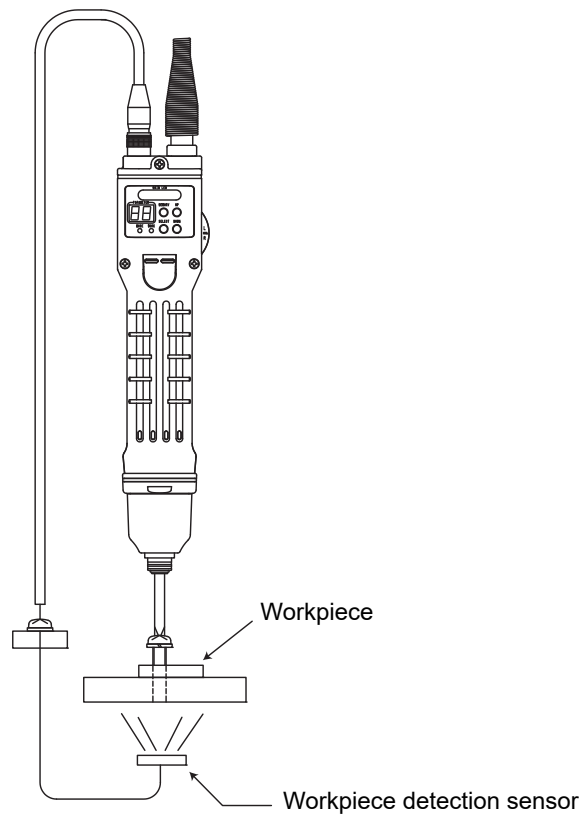

Basic operation

When workpiece is detected, the workpiece LED lights in green and the electric screwdriver becomes operable.

When workpiece is not detected (workpiece LED lights off), the electric screwdriver is not operable.

If workpiece is removed before completing a series of tightening (before the screw count reaches the set value), NG occurs and the parameter LED displays E7.

Set workpiece again or input the reset signal.

If workpiece is removed after completing a series of tightening (after the screw count reaches the set value), the procedure comes to completion.

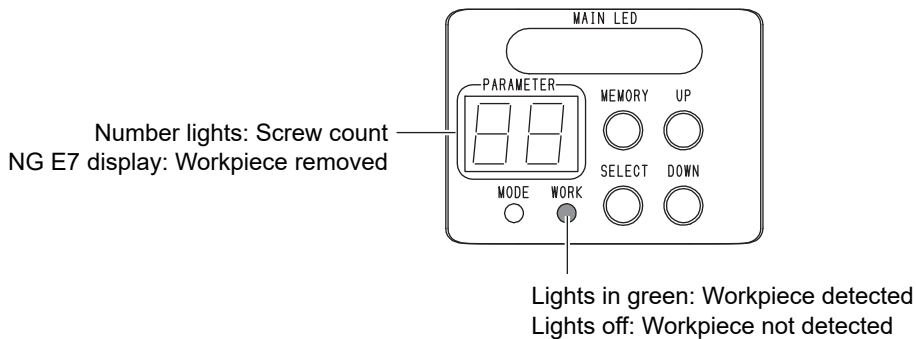

Adjusting the workpiece setup time

You can adjust the time from when workpiece is set (workpiece is detectable) to when the workpiece LED lights. During this period, you can check whether incorrect workpiece is set. Within the period, moving workpiece does not cause NG. Also, the electric screwdriver does not operate.

- 1 Press and hold the [MEMORY] button and [SELECT] button**
The mode enters function setting mode.
- 2 Press the [SELECT] button to select function No. 2**
- 3 Use the [UP] or [DOWN] button to select the workpiece setup time (0.1 - 9.9 sec.)**
- 4 Press and hold the [MEMORY] button to save the setting**

Start timing of workpiece setup NG

You can decide at which point workpiece NG starts (NG E7 in case workpiece is removed half way through).

- 1 Press and hold the [MEMORY] button and [SELECT] button**
The mode enters function setting mode.
- 2 Press the [SELECT] button to select function No. 3**
- 3 Use the [UP] or [DOWN] button to select the workpiece setup NG timing**

Setting		Details
0	Upon setting a workpiece	Set workpiece (workpiece LED lights) → Remove workpiece → NG
1	When workpiece is set up and the screwdriver rotates	Workpiece is set (workpiece LED lights) → Press start switch of electric screwdriver → Remove workpiece → NG Set workpiece (workpiece LED lights) → Remove workpiece → NG does not occur * This function is useful if workpiece is set but is temporarily removed for such reasons as position adjustment or setting parts on the workpiece.

- 4 Press and hold the [MEMORY] button to save the setting**

Adjusting the OK signal output

When inputting the workpiece signal, it is possible to decide at which point the OK signal is output. The OK signal is output when a series of operations is completed. The main LED lights in blue.

- 1 Press and hold the [MEMORY] button and [SELECT] button**
The mode enters function setting mode.
- 2 Press the [SELECT] button to select function No. 4**
- 3 Use the [UP] or [DOWN] button to set the screw fastening confirmation time (0 - 9.9 sec.)**
- 4 Press the [SELECT] button to select function No. 5**
- 5 Use the [UP] or [DOWN] button to set the OK signal output timing**

Setting		Details
0	When the set count ends	Set count ends → Screw fastening confirmation time → OK signal output → Remove workpiece (OK signal output OFF) By pressing the [UP] button during the screw fastening confirmation time, an OK signal is output by skipping the screw fastening confirmation time
1	When the set count ends and workpiece is removed	Set count ends → Screwdriver becomes operable regardless of the screw fastening confirmation time (the [UP] button disables the OK signal output) → Remove workpiece → OK signal output (0.1 sec.) * This setting is used when the OK signal output is based on workpiece removal regardless of the set screw fastening confirmation time.

- 6 Press and hold the [MEMORY] button to save the setting**

OK signal output timing "0"

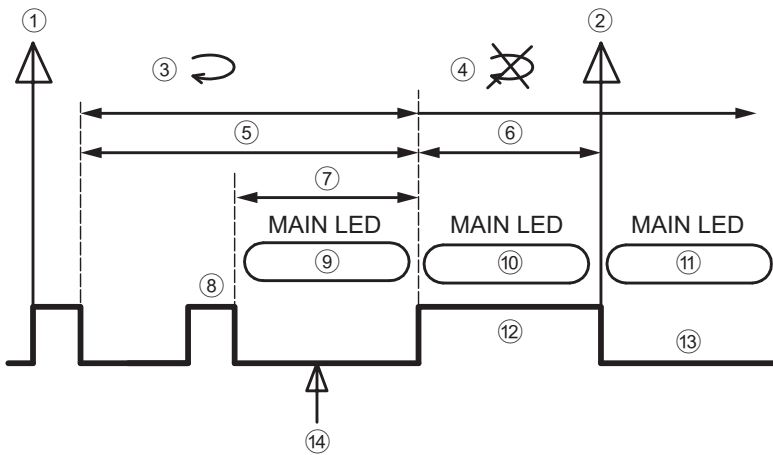

- ① Workpiece setup
- ② Workpiece removal
- ③ Electric screwdriver operates
- ④ Electric screwdriver not operable
- ⑤ Workpiece removal NG
- ⑥ Workpiece removal OK
- ⑦ Screw fastening confirmation time
- ⑧ Completion of screw tightening set count
- ⑨ Lights in green
- ⑩ Lights in blue
- ⑪ Lights off
- ⑫ OK signal output
- ⑬ OK signal OFF
- ⑭ Pressing the [UP] button skips the step and outputs the OK signal

OK signal output timing "1"

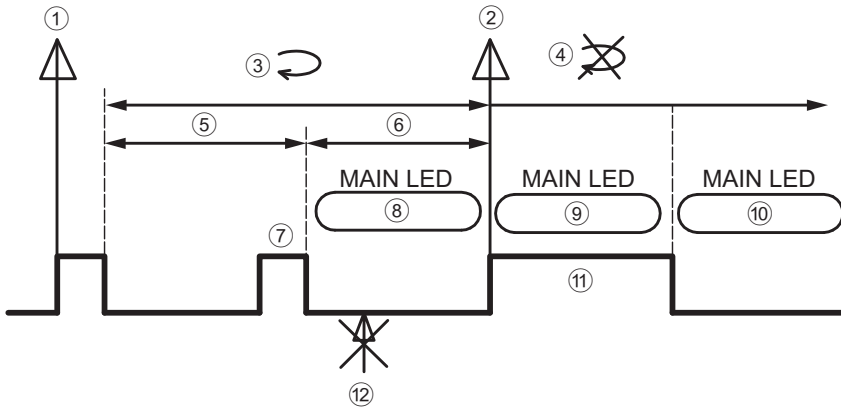

- ① Workpiece setup
- ② Workpiece removal
- ③ Electric screwdriver operates
- ④ Electric screwdriver not operable
- ⑤ Workpiece removal NG
- ⑥ Workpiece removal OK
- ⑦ Completion of screw tightening set count
- ⑧ Lights in green
- ⑨ Lights in blue
- ⑩ Lights off
- ⑪ OK signal output for 0.1 sec.
- ⑫ The OK signal is not output with the [UP] button

Selecting the NG signal output

You can select the NG signal to be output to outside from three patterns.

- 1** Press and hold the **[MEMORY]** button and **[SELECT]** button
The mode enters function setting mode.
- 2** Press the **[SELECT]** button to select function No. 8
- 3** Use the **[UP]** or **[DOWN]** button to set the NG signal output

Setting		Details
0	All NG output	Outputs all NG displays from E1 to E9
1	Screwdriver NG output	Outputs all other than the NG display E7 (workpiece is removed)
2	Workpiece setup NG output	Outputs NG display E7 only (the workpiece is removed)

- 4** Press and hold the **[MEMORY]** button to save the setting

Resetting operation

If a problem occurs on the workpiece during screw tightening and the workpiece needs to be removed, you can reset the series of operations.

CAUTION

- Make sure to connect an external power supply.
- For connection, use thick wire as much as possible. (AWG20 or more is recommended)
- For connection of an external signal, use a commercially available terminal block.

See "Connection example of input signal" (p. 47) to connect the reset switch.

By pressing the 0.5 sec. reset switch, the status can be returned to the previous status that was in effect before the workpiece is set. Also, reset is possible during the OK signal output period.

Connected signal	Pin No.	Signal cable (sold separately) wiring color
+24 DC power	1	Red
Reset signal	3	Green
0 VDC	12	Black

Link function

⚠ CAUTION

- **When the link function is used, the following functions cannot be used.**
Output of channel switching signal
Forced stop signal
- **With one workpiece signal input, all linked electric screwdrivers operate.**
It is not possible to assign individual workpiece signal input to each electric screwdriver.
- **Always connect an external power supply and reset switch.**
- **For connection, use thick wire as much as possible. (AWG20 or more is recommended)**
- **For connection of an external signal, use a commercially available terminal block.**

A function that links up to 10 electric screwdrivers is called the link function.

Because the screwdriver starts in order upon connection, you can understand which electric screwdriver is used according to the screw tightening order, achieving a work system with less error.

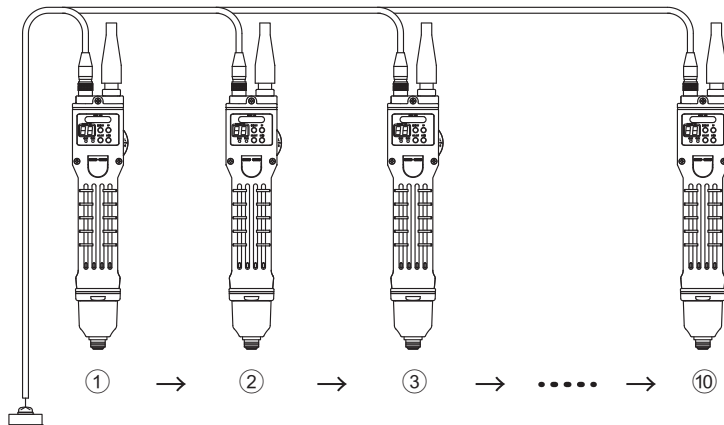

Electric screwdrivers start in order of connection and when the set screw count is reached, the next connected electric screwdriver becomes operable.

One electric screwdriver is operated at a time. Two or more screwdrivers cannot be operated at the same time.

1 Turn off the power of the connected electric screwdriver

2 Connect (wire) the I/O signal

Refer to the example of link connection and settings (p. 56) to connect an external power supply, switches and sensors. To use the link function, an external power supply and reset switch are required.

3 Turn ON the power of the electric screwdriver

4 Press and hold the [MEMORY] button and [SELECT] button

The mode enters function setting mode.

5 Use the [SELECT] button, [UP] button, and [DOWN] button to set the following functions

Function No.	Function	Setting
5	OK signal output timing	0: When the set count ends
13	Pin No. 7 output switching	1: LINK-OUT
14	Pin No. 4 input switching	1: LINK-IN

6 Press and hold the [MEMORY] button to save the setting

Make the same setting for all connected electric screwdrivers.

Example of link connection

Example 1: Link connecting two electric screwdrivers

The main LED of the operable electric screwdriver lights in blue until the start switch is pressed.

- ① The main LED of electric screwdriver 1 lights in blue
- ② After the screw tightening set count of electric screwdriver 1 is completed, electric screwdriver 2 becomes operable (the main LED lights in blue)
- ③ After the screw tightening set count of electric screwdriver 2 is completed, operation ends
- ④ Electric screwdriver 1 becomes operable again

When returning to the first screwdriver (example: a problem occurs halfway through the screw tightening of electric screwdriver 2), press the externally connected reset switch for 0.5 seconds.

- 1** Connect an external power supply to electric screwdriver 1 and 2
- 2** Connect the reset switch in such a way that the reset signal is commonly input to electric screwdrivers 1 and 2
- 3** Connect the OK signal of electric screwdriver 1 to the workpiece signal of electric screwdriver 2
- 4** Connect LINK-OUT of electric screwdriver 2 to LINK-IN of electric screwdriver 1
- 5** Set the function No. 1 (workpiece signal) to “0: Do not input” for electric screwdriver 1 and “1: Input” for electric screwdriver 2

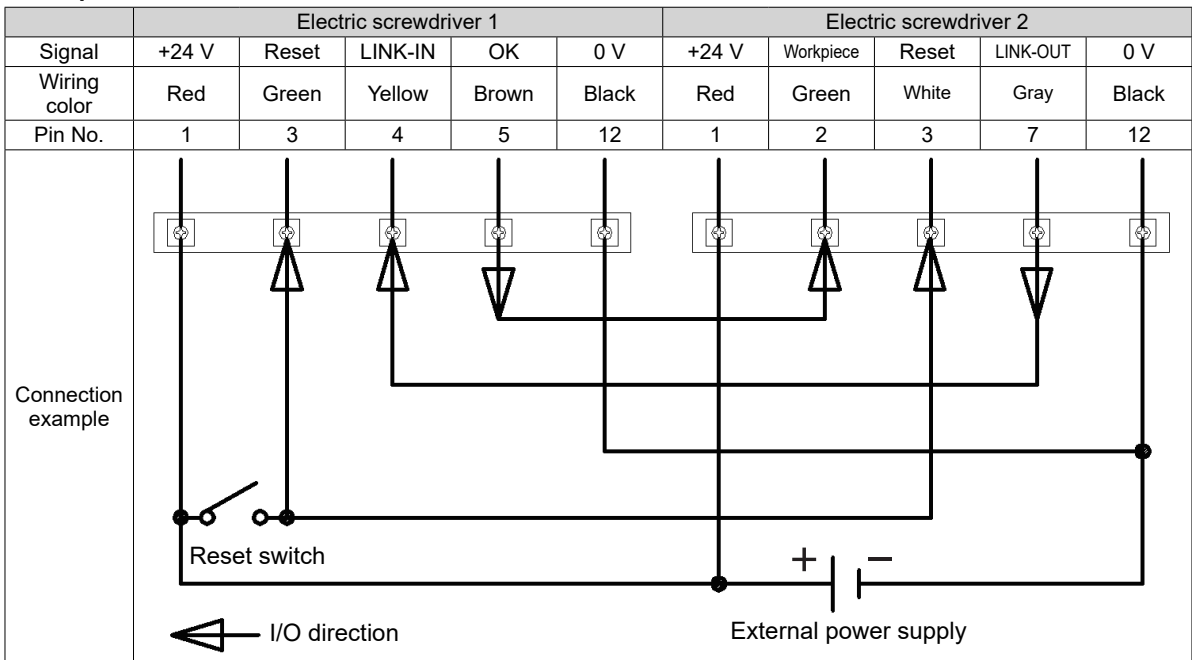

Example 2: Link connecting three or more electric screwdrivers

For three or more screwdrivers, you can add them using the same connection and setting method described for electric screwdriver 2 in the connection example. The connection example shows three units connected, e.g., electric screwdriver 1 → 2 → 3, in that order.

- 1** Connect an external power supply to all electric screwdrivers
- 2** Connect the reset switch to all electric screwdrivers in such a way that the reset signal is input commonly
- 3** Connect the OK signal of electric screwdriver 1 to the workpiece signal of electric screwdriver 2
Connect the electric screwdrivers 2 and 3 in the same way.
- 4** Connect LINK-OUT of electric screwdriver 3 to LINK-IN of electric screwdrivers 1 and 2
- 5** Set the function No. 1 (workpiece signal) to “0: Do not input” for the electric screwdriver 1 and “1: Input” for electric screwdrivers 2 and 3

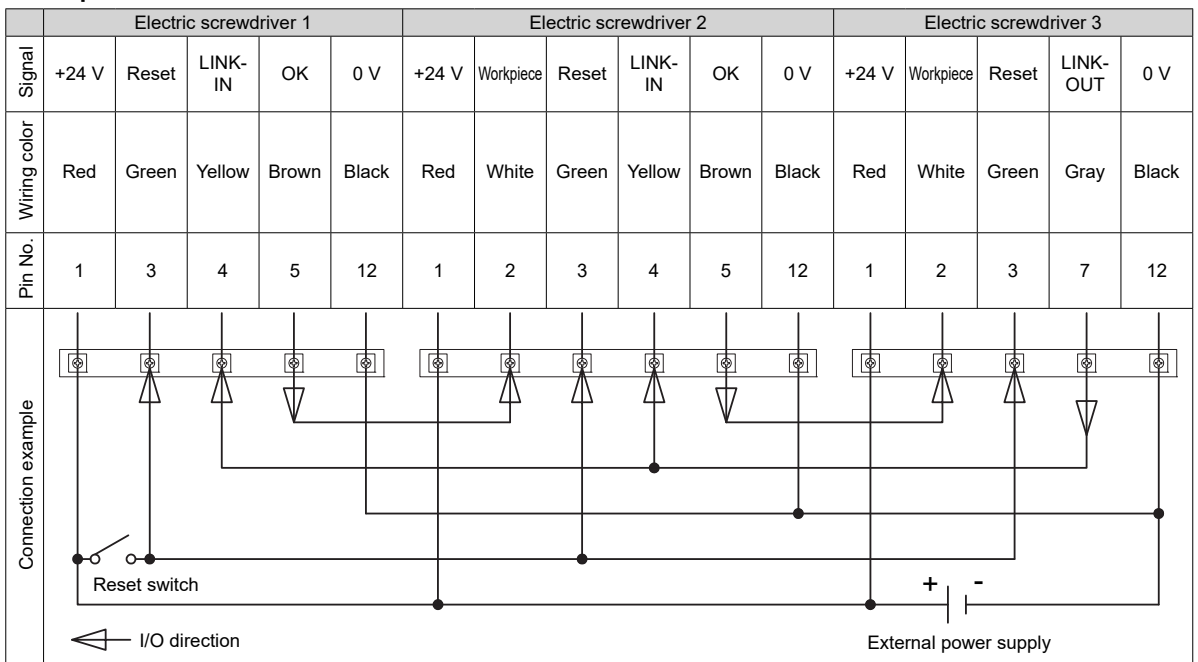

Example 3: Input the workpiece signal

CAUTION

- **A 2-wire sensor cannot be used.**
A 2-wire sensor has a flow of fine current even while OFF, and could cause a malfunction.
- **For the sensor, use a PNP output type 3-wire sensor.**
- **Depending on the sensor installation environment, a malfunction could occur due to noise.**
Make sure to take sufficient noise measures such as setting up grounding. For details, read the instruction manual of the sensor to be used.

When connecting three or more tools, the setting for the first screwdriver is different but the setting for the second and subsequent tools is the same as Example 2 and the operation is also the same as Example 2.

- 1** Connect an external power supply to electric screwdriver 1 and 2
- 2** Connect the reset switch in such a way that the reset signal is commonly input to electric screwdrivers 1 and 2
- 3** Connect the workpiece detection sensor to the workpiece signal of electric screwdriver 1
- 4** Connect LINK-OUT of electric screwdriver 2 to LINK-IN of electric screwdriver 1
- 5** Set the following functions

Function No.	Function	Electric screwdriver 1	Electric screwdriver 2
1	Workpiece signal	1: Input	1: Input
5	OK signal output timing	0: When the set count ends * For five tools, electric screwdrivers 1 to 4 are "0"	0: When the set count ends or 1: When the set count ends and the workpiece is removed * For five tools, only electric screwdriver 5 can be selected

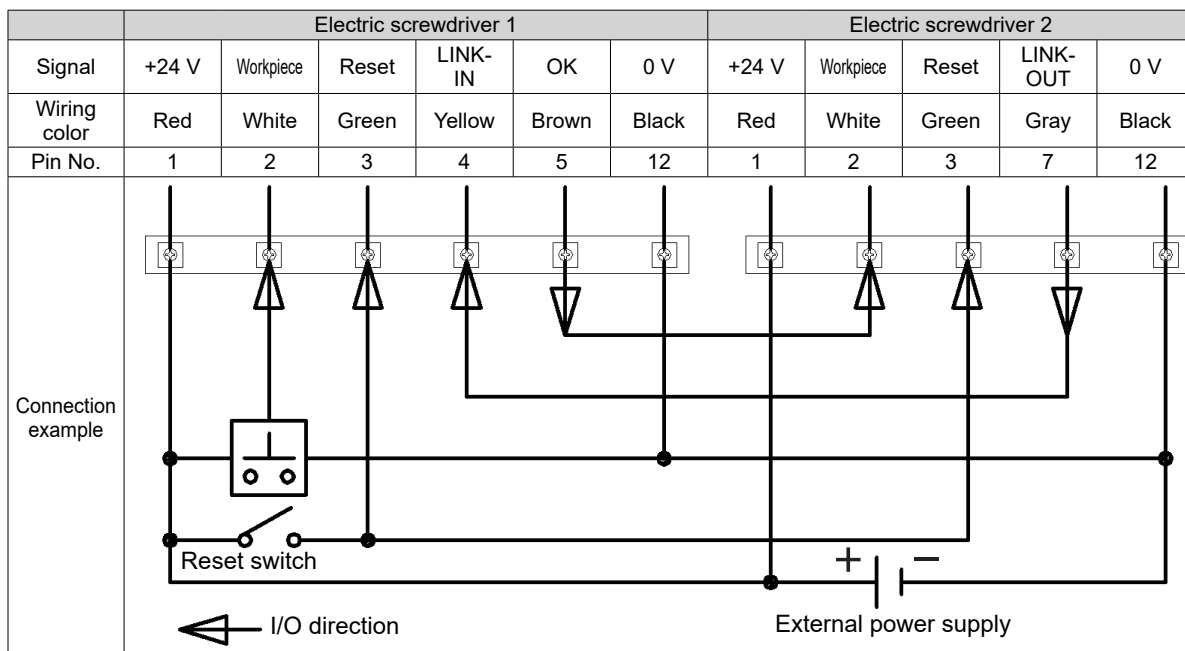

Forced stop signal

⚠ CAUTION

- When the force stop signal is used, the link function cannot be used.
- Make sure to connect an external power supply.
- For connection, use thick wire as much as possible. (AWG20 or more is recommended)
- For connection of an external signal, use a commercially available terminal block.
- A 2-wire sensor cannot be used.
A 2-wire sensor has a flow of fine current even while OFF, and could cause a malfunction.
- For the sensor, use a PNP output type 3-wire sensor.
- Depending on the sensor installation environment, a malfunction could occur due to noise.
Make sure to take sufficient noise measures such as setting up grounding. For details, read the instruction manual of the sensor to be used.

You can forcefully stop operation of an electric screwdriver externally. Forced stop signal allows you to control operation without turning off the electric screwdriver.

You can add conditions by combining workpiece signals, for example, place workpiece (workpiece signal ON, forced stop signal ON) → remove workpiece (workpiece signal ON, forced stop signal OFF) → operate electric screwdriver. Forced stop signal input turns ON and the electric screwdriver is stopped forcefully and then the workpiece LED goes off.

The forced stop signal input turns OFF and the electric screwdriver starts operating and then the workpiece LED lights in green.

1 Connect the I/O signal

Connection example

Connected signal	Pin No.	Signal cable (sold separately) wiring color
+24 DC power	1	Red
Forced stop signal	4	Yellow
0 VDC	12	Black

2 Press and hold the [MEMORY] button and [SELECT] button

The mode enters function setting mode.

3 Press the [SELECT] button to select function No. 14

4 Use the [UP] or [DOWN] button to set pin No. 4 input switching to “0: Forced stop signal”

5 Press and hold the [MEMORY] button to save the setting

Changing the channel with an external signal

⚠ CAUTION

- Make sure to connect an external power supply.
- For connection, use thick wire as much as possible. (AWG20 or more is recommended)
- For connection of an external signal, use a commercially available terminal block.

You can change the channel of an electric screwdriver externally. The channel is not switched during operation (rotation) and is changed when the start switch is released.

When the channel is switched by an external signal, the channel setting mode (screwdriver internal channel switching (p. 22)) cannot be used.

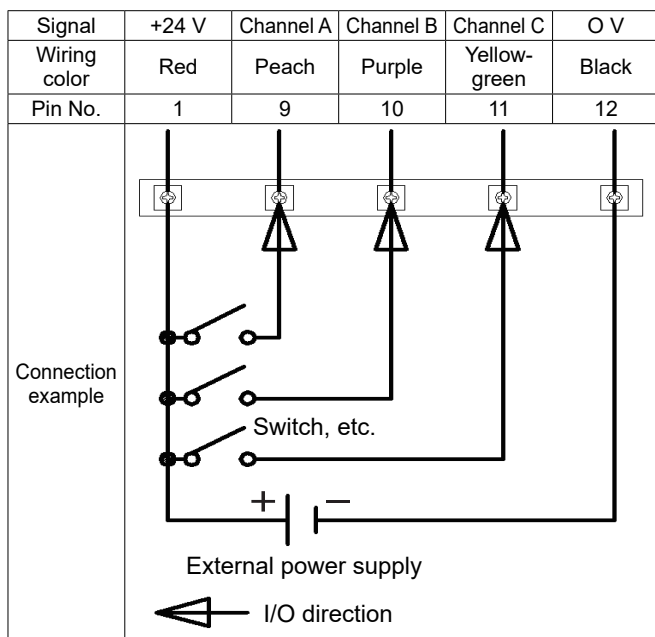

- 1 Press and hold the [MEMORY] button and [SELECT] button
The mode enters function setting mode.
- 2 Press the [SELECT] button to select function No. 12
- 3 Use the [UP] or [DOWN] button to set the channel switching method to “1: External signal”
- 4 Press and hold the [MEMORY] button to save the setting

Correspondence with screwdriver internal channel No.

Screwdriver internal channel No.	External signal		
	Channel A	Channel B	Channel C
1	Contact OFF	Contact OFF	Contact OFF
2	Contact OFF	Contact OFF	Contact ON
3	Contact OFF	Contact ON	Contact OFF
4	Contact OFF	Contact ON	Contact ON
5	Contact ON	Contact OFF	Contact OFF
6	Contact ON	Contact OFF	Contact ON
7	Contact ON	Contact ON	Contact OFF
8	Contact ON	Contact ON	Contact ON

14 Appendix

Troubleshooting

Symptoms	Location to investigate	Solution
The electric screwdriver does not operate	Is the power plug inserted into an outlet? Is power supplied to the outlet?	Properly insert the power plug into the outlet. Check the power supply.
	Is the workpiece signal set to "1: Input"?	Set up a workpiece or set the workpiece signal to "0: Do not input". (p. 19, p. 49)
	Is the changeover switch set to neutral?	Slide the changeover switch to the R or L side.
	Is the operation No. 7 "Lower limit of screw fastening time" set to "0 sec. (OFF)" when "Reverse after the lower limit of screw fastening time" is set in the auto reverse mode?	Set a numeric value for operation No. 7 "Lower limit of screw fastening time". Or set auto reverse mode to "0: OFF" and "1: Reverse after torque-up". (p. 18, p. 28)
	Is the setting mode other than screw fastening mode set?	Press and hold the [SELECT] button to return to screw fastening mode.
	Is the workpiece setup time too long? The tool does not operate during the workpiece setup time.	Shorten the workpiece setup time. (p. 51)
	Is the NG signal output time too long? The tool does not operate during the NG signal output time.	Shorten the NG signal output time. (p. 36)
	Is the signal line connected to the external signal connector? Is external 24 DC power supplied?	Properly connect the signal line to the external signal connector. Check the external power supply.
	Are the wires of the external signal input and output properly connected? Are electronic parts to be used properly connected?	Check the wiring. Also, carefully read the instruction manual of the electronic parts to be used.
	Is noise applied to the external signal line? Is the line bundled with the power cable?	Check by only connecting an electric screwdriver to the external signal line and power line. Make sure to take sufficient noise measures such as setting up grounding.
	Is a forced stop signal being input?	If a forced stop signal is turned ON, the electric screwdriver does not operate. Turn it OFF.
	Is NG display E1 to E9 being displayed?	Check the content of the NG display. (p. 20)
	Has the security has been set?	Use a remote controller to cancel it.
Has each setting been set according to the instruction manual?	If you forgot about the setting, perform initialization. (p. 21)	
E8 (Motor-Lock) occurs frequently	Does the output torque value and speed level have room?	Decrease the output torque value or decrease the speed level. The specification range is a standard. Depending on the fastening conditions, it may not be possible to use the function. (p. 7)
	Has the torque adjustment ring been raised too much?	Lower the torque adjustment ring. If it is raised too much, it touches the torque spring and torque cannot reach the set torque. (p. 17)
	Is E8 displayed under no load status?	If E8 is displayed under no load status, a failure is suspected.
	Is the bit rotated under no load status?	If the bit does not rotate and E8 is displayed a failure is suspected.

Symptoms	Location to investigate	Solution
The output torque is low Screws cannot be tightened	Are you using a combination of NITTO KOHKI measuring devices for measurement?	Use a combination of NITTO KOHKI's measuring devices for measurement. (p. 5)
	Are you turning the torque adjustment ring clockwise? Has the output torque dropped?	The output torque decreases as the tool is used. Turn the torque adjustment ring clockwise. (p. 17)
	Did you check the correlation between the output torque occurred on screws and the output torque measured using a measurement device?	The output torque occurred on screws and the output torque measured by the measurement device are different. Adjust the output torque according to the screw fastening conditions. (p. 5)
	Is the bit worn out?	When the bit is worn out, it becomes difficult to transmit torque to screws. Replace the bit. (p. 9)
	Are you tightening while crushing a part between the screws. Has regression loosening occurred?	Torque may not be transmitted. Crush the part once and then tighten the screw. Auto reverse mode is in effect. (p. 28)
	Has axial force occurred to the screw?	Without axial force, even though the output torque is increased, screws are not tightened. Review the screw fastening conditions. Also, by tightening at low speed, it becomes easier to transmit torque.
	Has initial loosening occurred?	Initial loosening occurs as a result of permanent set in fatigue when fine irregularities such as surface roughness are lost over time after the screw is tightened or outside force is applied. Tighten the screw again. When using auto reverse mode, torque reaches the set torque once, thus it is more effective than single tightening. (p. 28)
	Has the permanent set in fatigue occurred due to permanent deformation of sealing material such as the gasket?	Carefully check the screw fastening conditions and set the output torque and rotation level. Depending on the material, torque may not be transmitted if a screw is tightened at high speed.
	Is the area surrounding the screw at a high temperature?	Screws could be extended or loosened by temperature changes. Review the screw fastening conditions and process.
The output torque is high Screws are tightened too much	Have you considered the occurrence of vibration or outside force?	Loosening of screw occurs if no measures are taken for vibration or outside force. Take appropriate loosening prevention measures.
	Did you check the correlation between the output torque occurred on screws and the output torque measured using a measurement device?	The output torque occurred on screws and the output torque measured by the measurement device are different. Adjust the output torque according to the screw fastening conditions. (p. 5)
	Have you attached a heavy jig or a jig having a large radius at the end?	After the torque reaches the set torque, the inertial force of the jig might have been transmitted to screws. Review the jig and reduce the weight or size of the jig.
The torque scale and output torque do not match	The torque scale is a standard. The output torque range is not guaranteed. The output torque range sometimes differs from the scale but this is not a product error. (p. 7)	
The electric screwdriver gets hot	Is the ON time of the electric screwdriver too long? Alternatively, is the OFF time too short?	Review the operation time. The rated operating time is 0.5 sec. ON and 3.5 sec. OFF. Aim at 15 screws per minute. (p. 5)
	Even though the output torque is set to the specification lower limit value, does the screwdriver get hot to a level where you cannot touch it?	When the output torque becomes higher, the electric screwdriver becomes hot. If it gets hot to a level where you cannot touch even with the specification lower limit value, a failure is suspected.

Symptoms	Location to investigate	Solution
Speed varies	Is the electric screwdriver generating heat? Are you using the same electric screwdriver?	The specification value is a standard. The speed of electric screwdrivers varies depending on the temperature of the unit, mechanical loss and grease conditions. It could vary depending on differences in the tool itself. (p. 5, p. 7)
The setting conditions are unknown	Did you make a note of the settings? Did you check the channel currently set (p. 23)?	For the current set channel and motion setting, see p. 23. To check the function setting, press the [SELECT] button in function setting mode. (p. 34)

Maintenance and inspection

WARNING

- Before performing maintenance and inspection, always turn off the power.
- Do not disassemble or alter the tool.
- Use genuine parts.

CAUTION

- For repair or part replacement, ask your dealer.
Repair requires special knowledge and skills. If repair is performed at a place other than a specialty store, the tool may not demonstrate its full performance or it could lead to an accident or injury.
- Request repair with the failed status kept intact.
When requesting a repair, do not throw away damaged parts. It could be important information for investigating the failure cause so do not change the status.

For the purpose of making proper use, request the following check and maintenance by an authorized service facility.

Routine inspections and Parts to be replaced	DLV30S series				DLV45S series, DLV70S series			
	Number of Tightening (million)							
	0.5	1.0	1.5	2.0	0.25	0.5	0.75	1.0
Routine inspection								
(1) Operation check	○	○	○	○	○ ^{*1}	○ ^{*1}	○ ^{*1}	○ ^{*1}
(2) Grease-up				○		○ ^{*2}		○ ^{*1}
Parts to be replaced								
(1) Motor assembly				○		○ ^{*2}		○ ^{*1}
(2) Gear				○		○ ^{*2}		○ ^{*1}
(3) Rollers and Balls				○		○ ^{*2}		○ ^{*1}
(4) Bearing				○		○ ^{*2}		○ ^{*1}

*1: DLV45S series, DLV70S series

*2: DLV70S series

Inspection locations	CAUTION
Cable	Failure to perform inspection could result in fire or electric shock. <ul style="list-style-type: none"> ● Check if cables are damaged and if found, stop using the tool. ● Do not store the cord by wrapping it around the main unit. If it is stored with the cable wrapped around the main unit, immediately change the storage method.
Power plug	Failure to perform inspection could result in fire or electric shock. <ul style="list-style-type: none"> ● Check for damage on the power plug. If damaged, stop using it. ● Check if the power plug has dust or metallic material adhering to it. If attached, disconnect the power plug and use a dry cloth to remove it. ● Check that the power plug is properly inserted into the outlet all the way to the base. ● Check for play in the power plug and outlet.
Bit	<ul style="list-style-type: none"> ● Check for wear or damage on the bit end. Using the tool as is, the screw head could be damaged or torque may not be transmitted. Replace with a new bit.
Main unit	<ul style="list-style-type: none"> ● Check for damage, cracks or breaks on the main unit. ● Check the screws on the main unit (including accessory Pistol Grip). If screws are loose, tighten them.
Output torque	<ul style="list-style-type: none"> ● Use a combination of NITTO KOHKI's measuring devices to measure the output torque. ● If the output torque value has decreased, turn the torque adjustment ring to adjust the torque.
Screw fastening time	<ul style="list-style-type: none"> ● Use the screw fastening time measurement function to check if the screw fastening time has not changed. ● The speed is a standard. It changes by the temperature of the tool, mechanical loss, and grease conditions.
Care	<ul style="list-style-type: none"> ● If the main unit is stained, use a cloth soaked in soapy water and wrung out well to wipe off the stain. The tool does not have a waterproof structure and if water enters inside, it could fail. ● Because the main unit uses plastic, the following chemicals cannot be used. Acetone, benzene, thinner, ketone, ether, trichlorethylene and other similar chemicals

Disposal

- Separate power tools, accessories, and packing materials for environmentally-friendly recycling.
- Do not dispose of the power tool as household garbage.
- When disposing of electric tools, give them to NITTO KOHKI or your dealer.
- Within the EU region, Waste Electrical and Electronic Equipment (WEEE) Directive 2002/96/EC is rolled out in domestic laws and it is prescribed to separately collect power tools, which are recycled and reused.



Separately-sold products

The following products are sold separately. To purchase these items, please contact your dealer where you purchased your electric screwdriver.

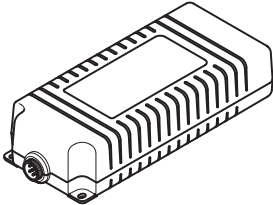
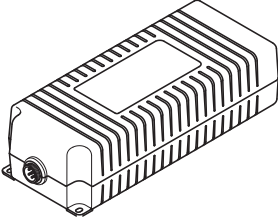
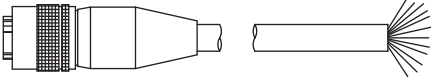
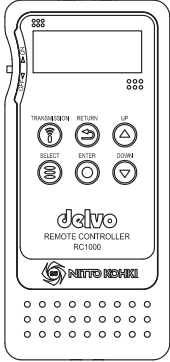
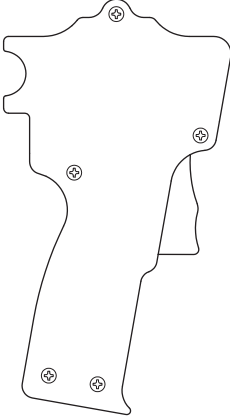
Product name (model)	Appearance	Specification, etc.
Power supply (DEA0151N-AZ)		<ul style="list-style-type: none"> ● 100 VAC - 240 VAC ● Maximum Rated Power 150W ● Compatible models DLV30S06P/DLV30S06L DLV30S12P/DLV30S12L DLV45S06P/DLV45S06L
Power supply (DEA0241N-AZ)		<ul style="list-style-type: none"> ● 100 VAC - 240 VAC ● Maximum Rated Power 240W ● Compatible models All models described in this document
Signal cable (DLW9090)		External signal connection cable <ul style="list-style-type: none"> ● Cable length: 3 m ● Terminal processing: Discrete wire ● Compatible models All models described in this document
Remote controller (RC1000)		<ul style="list-style-type: none"> ● Compatible models All models described in this document
Pistol Grip (DLW2300ESD)		Grip used for reaction force measures or transverse tightening <ul style="list-style-type: none"> ● DLV45S/DLV70S series standard accessories ● Can be used for DLV30S series as well

External dimensions

Front view
DLV30S06L-AY
DLV30S12L-AY
DLV30S20L-AY

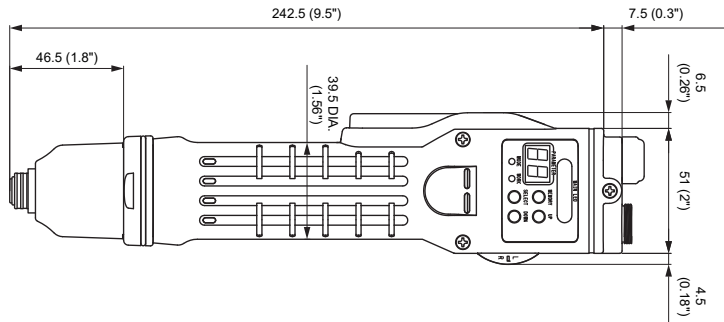

Front view
DLV30S06P-AY
DLV30S12P-AY
DLV30S20P-AY

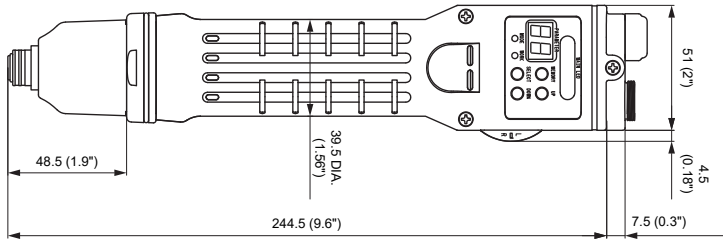

Side view
Common to DLV30S

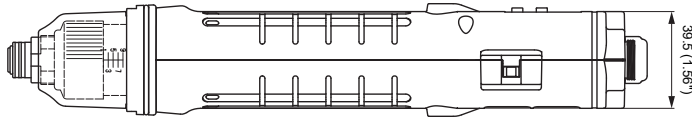

Front view
DLV45S06L-AY
DLV45S12L-AY
DLV70S06L-AY

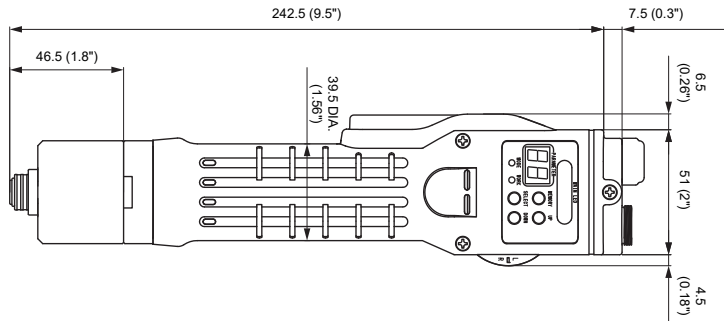

Front view
DLV45S06P-AY
DLV45S12P-AY
DLV70S06P-AY

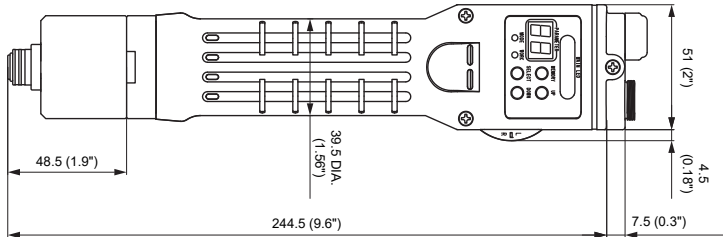

Side view
Common to DLV45S
Common to DLV70S

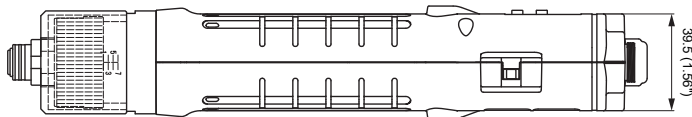

Glossary

Term	Description
A	
Auto reverse mode	Automatically changes the rotation of the electric screwdriver to the reverse direction
B	
Bit	The fitting part that transmits torque to screws It is also known as a socket
Bit Breaks function	A function to prevent the bit from inertial rotation when the start switch is released
Bit Joint	A jig made by NITTO KOHKI to be used to measure torque
C	
Channel	The folder in which the motion settings are saved
Channel switching	The function that calls a channel (motion setting) you wish to use
Count method	The method of counting screw tightened
Count return function	A function to return the screw count by one screw
Coupling	The part that secures the frame handle so that it does not open The color and material vary depending on the model
D	
[DOWN] button	Decreases the set value number
Driver NG sound	The sound issued when NG (other than E7) occurred in the electric screwdriver
E	
External signal connector	Part for connecting to external signals
F	
Forced stop signal	A function that externally and forcefully stops the motion (rotation) of the electric screwdriver
Frame handle	The resin part of the main unit Also called a cover or housing
Function setting mode	The mode used to set various functions
I	
Initialization	Returns motion settings, function settings or all settings to the factory default
Input signal	Signal input to the electric screwdriver
K	
Keylock	Locks button operations
L	
Lever start type	The start method with which the tool rotates by pressing the lever
Link function Link connection	Function that links multiple electric screwdrivers
LINK-IN	Signal input to all electric screwdrivers in the prior stage of the last electric screwdriver in a link connection
LINK-OUT	Signal output by the last electric screwdriver in a link connection
M	
Main LED	Notifies various operations and settings by lighting, flashing, and color
[MEMORY] button	Saves the setting
Mode LED	Lights when a specific operation status is set
Motion setting mode	The mode used to set the screw count, speed and screw fastening time
N	
NG display	Displays E1 to E9 NG operation
NG display continues	The function to continue displaying the NG signal output on the parameter LED
NG signal output time	Duration to output the NG signal or duration to display the NG content on the parameter LED During this period, the tool does not operate (rotate)
No load speed	The speed in the status where load (torque, etc.) is not applied to the electric screwdriver
O	
OK signal	The signal output issued upon completion of a series of operations
OK signal output timing	Timing to output the OK signal
OK sound	The sound issued upon completion of a series of operations
Open collector	One of the methods of outputting electronic circuits With this output method, the collector of an output transistor is not connected anywhere inside and signals are output as is to one terminal

Term	Description
Output signal	The signal output by the electric screwdriver
P	
Parameter LED	Displays the screw count or various set values
Photocoupler	A device that internally converts electric signals to light and then returns it to electric signals to transmit signals while electrically insulating the signal
Pistol Grip	An accessory used to absorb reaction of screw tightening or for transverse tightening
PNP output type 3-wire sensor	The type wherein a load is connected between the minus side of the power supply and sensor output
Push start type	A method of starting tool rotation when pressing in the bit direction
R	
Remote controller	A device that can be used to set the electric screwdriver via infrared communication
Reset	Used to cancel or delete a setting
S	
[SELECT] button	Selects or cancels the setting
Screw fastening confirmation time	Time to check the screw tightening after the screw count is reached During this time, the tool operates (rotates) freely
Screw fastening mode	Operable (rotatable) mode Basic operation status
Screw fastening time	Duration to tighten a screw The upper limit and lower limit values can be set
Screw fastening time measurement mode	The mode used to measure the screw fastening time Updates the minimum and maximum values
Screw tightening completion sound	The sound issued when screw tightening is completed as set each time a screw is tightened
Speed level	A standard speed Lv1 is the minimum speed and Lv9 is the maximum speed
Start timing of workpiece setup NG	Time when a workpiece setup NG E7 is displayed
Suspension Bail	Used to suspend the main unit
T	
Time display	0.01 sec. intervals is displayed without "." and 0.1 sec. intervals is displayed with "."
Torque adjustment ring	The part used to adjust the torque Turning clockwise increases the torque and counterclockwise decreases the torque
Torque adjustment ring cover	Parts that prevent unnecessary torque setting changes
Torque Checker	NITTO KOHKI torque measuring instrument
Torque scale	A mark that indicates the torque adjustment ring This is not the torque value
Torque spring	A spring used to adjust the output torque
Torque-up	The torque reaches the set torque and the screwdriver automatically stops with a clicking sound
U	
[UP] button	Increases the set value number
W	
Workpiece	The subject to which screws are tightened
Workpiece LED	Lights when the electric screwdriver becomes operable (rotatable)
Workpiece setup NG sound	Sound issued when a workpiece setup NG E7 occurred
Workpiece setup time	A period during which whether the workpiece is incorrectly set up is checked During this period, even when the workpiece is removed, NG does not occur (the electric screwdriver does not operate)
Workpiece signal	Signal input when workpiece is set up

Index

- A**
- Adjusting the OK signal output..... 52
 - Auto reverse mode..... 28
- B**
- Bit..... 9
 - Bit Breaks function..... 40
- C**
- Changeover switch..... 14
 - Channel..... 22
 - Channel setting mode..... 22
 - Channel switching..... 60
 - Connection Cord..... 13
 - Count return function..... 39
 - Coupling..... 3
- D**
- [DOWN] button..... 4
- E**
- External signal connector..... 44
- F**
- Fixing jig..... 12
 - Forced stop signal..... 59
 - Frame handle..... 3
 - Function setting mode..... 19, 34
- I**
- Initialization..... 21, 24
 - I/O circuit..... 45
- K**
- Keylock..... 41
- L**
- Lever start type..... 15
 - Link function..... 55
- M**
- Main LED..... 4
 - [MEMORY] button..... 4
 - Mode LED..... 4
 - Motion setting mode..... 18, 24
- N**
- NG display..... 20
 - NG signal output..... 54
 - NG signal output time..... 36
- O**
- Operation mode..... 18
 - Output torque..... 7, 17
- P**
- Parameter LED..... 4
 - Pistol Grip..... 2, 11, 65
 - Power supply..... 65
 - Push start type..... 15
- R**
- Remote controller..... 42, 65
 - Reset..... 38
- S**
- Screw count..... 25
 - Screw fastening confirmation time..... 35
 - Screw fastening mode..... 14
 - Screw fastening time..... 31
 - [SELECT] button..... 4
 - Separately-sold products..... 65
 - Signal cable..... 65
 - Speed level..... 8, 26
 - Start timing of workpiece setup NG..... 51
 - Suspension Bail..... 2, 9
- T**
- Time display..... 19
 - Torque adjustment ring..... 3, 10, 17
 - Torque adjustment ring cover..... 3, 10, 17
 - Torque Checker..... 6
 - Torque scale..... 3
 - Torque spring..... 2, 10
 - Torque-up..... 16
- U**
- [UP] button..... 4
- W**
- Workpiece LED..... 4
 - Workpiece setup time..... 51
 - Workpiece signal..... 49

Setting memo

Motion setting

Motion No.	Motion	Setting range (default)	Channel							
			1	2	3	4	5	6	7	8
1	Screw count	1 - 99 screws (1)								
2	Speed level at start	Level 1 - 9 (L9)								
3	Rotation time at start	0 - 9.9 sec. (0)								
4	Speed level at middle	Level 1 - 9 (L9)								
5	Rotation time at middle	0 - 9.9 sec. (0)								
6	Speed level at finish	Level 1 - 9 (L9)								
7	Lower limit of screw fastening time	0 - 9.9 sec. (0)								
8	Upper limit of screw fastening time	0 - 9.9 sec. (0)								
9	Auto reverse mode setting	0 - 2 (0)								
10	Reverse speed level	Level 1 - 9 (L9)								
11	Reverse rotation	0 - 9.9 sec. (0)								

Function setting

Function No.	Function	Setting details (default)	Set value
1	Workpiece signal	0: Do not input / 1: Input (0)	
2	Workpiece setup time	0 sec.: OFF / 0.1- 9.9 sec.: 0.1 sec. intervals (0)	
3	Start timing of workpiece setup NG	0: When workpiece is set / 1: When workpiece is set and the screwdriver rotates (0)	
4	Screw fastening confirmation time	0 sec.: OFF / 0.1- 9.9 sec.: 0.1 sec. intervals (0)	
5	OK signal output timing	0: When the set count ends / 1: When the set count ends and the workpiece is removed (0)	
6	NG signal output time	0 sec.: OFF / 0.1- 9.9 sec.: 0.1 sec. intervals (0.1)	
7	NG display	0: Do not continue / 1: Continue (0)	
8	NG signal output selection	0: Output all NGs / 1: Output screwdriver NG / 2: Output workpiece setup NG (0)	
9	Count return function	0: Do not use / 1: Use (0)	
10	Count method	0: Count down / 1: Count up (0)	
11	Bit Breaks function	0: Do not use / 1: Use (0)	
12	Channel switching method	0: Inside screwdriver / 1: External signal (0)	
13	Pin No. 7 output switching	0: Output channel switching signal / 1: LINK-OUT (0)	
14	Pin No. 4 input switching	0: Forced stop signal / 1: LINK-IN (0)	
15	Screw fastening completion sound setting	0: OFF / 1: Sounds beep for each screw (1)	
16	OK sound setting	0: OFF / 1: Pi Pi Pi / 2: Pin-Pon / 3: Do Re Mi / 4: Pi Po / 5: Pi-Pi Pi-- (1)	
17	Workpiece setup NG sound setting	0: OFF / 1: Bu Bu Bu / 2: Bu-- Bi-- / 3: Do Si La / 4: Bu-- / 5: Bu-Bu Bu-- (1)	
18	Screwdriver NG sound setting	0: OFF / 1: Bu Bu Bu / 2: Bu-- Bi-- / 3: Do Si La / 4: Bu-- / 5: Bu-Bu Bu-- (1)	
19	NG output setting during free rotation	0: Output NG / 1: Do not output NG	