

Compressor

Model **AC0301A**

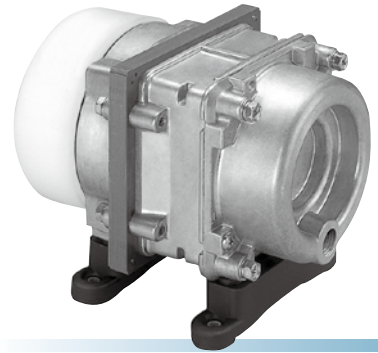

Airflow & Power Consumption

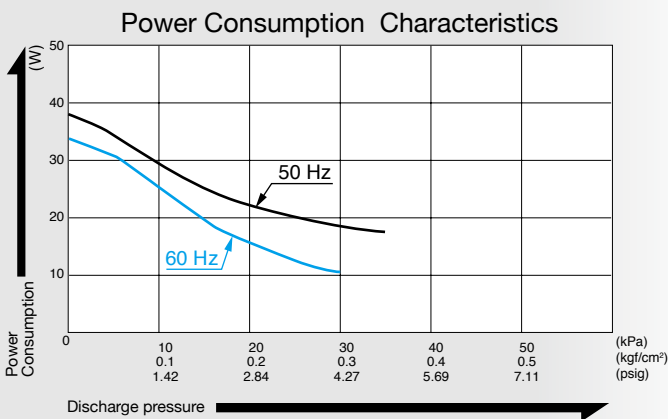
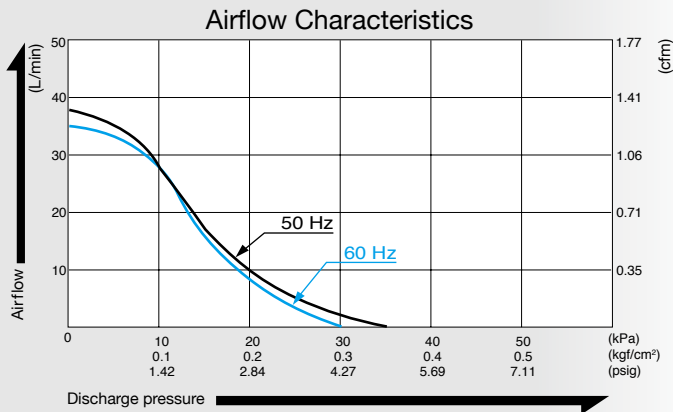

Specifications

Rated Pressure	10 kPa (0.1 kgf/cm ²) 0.1 bar 1.42 psig	
Rated Airflow	28 L/min 0.99 cfm	
Maximum Pressure	30 kPa (0.3 kgf/cm ²) 0.3 bar 4.27 psig	
Rated Voltage	115 V AC	230 V AC
Power Consumption	25 W	29 W
Rated Frequency	60 Hz	50 Hz
Rated Performance	10,000 hours	
Outlet	ISO Rc 1/4	
Duty Cycle	Continuous	
Coil Insulation Class	E or its equivalent and B for UL	
Mounting Dimensions	68 (L) x 84 (W) mm 2 - 43/64" (L) x 3 - 5/16" (W)	
Weight	1.9 kg 4.2 Lbs	
Leadwire Length	200 mm 7 - 7/8"	

Application Examples

Liquid Mixer



Seat Lifter

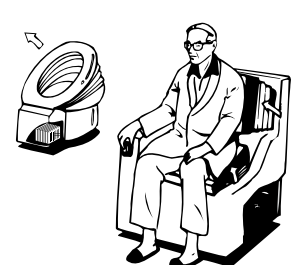

External Dimensions (Unit: mm)

