

**HA07-1624**



MODEL

# HA07-1624

## Specifications

<b>Model</b>		<b>HA07-1624</b>
<b>Max. Throat Depth</b>	inch (mm)	2-3/4" (70)
<b>Punching Capacity (for Mild Steel)</b>	<b>Max. Punching Diameter</b>	15/16" (24)
	<b>Max. Punching Thickness</b>	5/8" (16)
<b>Hole Making Time</b>	sec	Punching Time 16.5
<b>Allowable Max. pressure</b>	psi (kg/cm <sup>2</sup> )	10,000 psi (700)
<b>Max. Output</b>	lbf (tf)	97,020 (49)
<b>Ram Stroke</b>	inch (mm)	1" (25)
<b>Mass (Weight)</b>	lbs (kg)	63 (28.5)

HA07-1624

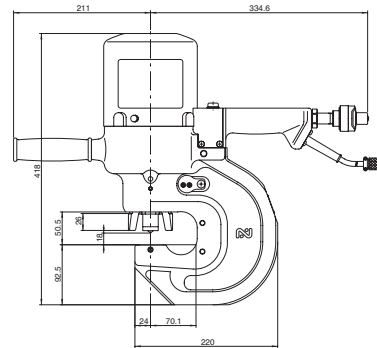
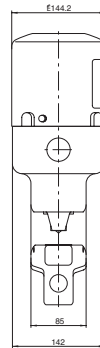

## Standard Accessories for HA07-1624

- Hose cord assembly
- 22 mm "D" series punch & die
- Sub handle assembly
- Spanner wrench
- 4 mm Allen wrench
- Tool box